



Type EV-2H

Aluminum Vertical
Break Disconnect
Switch

up to 245 kV

INSTALLATION &

INSTRUCTION

MANUAL

The Quality Name in High Voltage Switching

Safety Information

WARNING

IMPROPER HANDLING, INSTALLATION, OPERATION OR MAINTENANCE OF THIS EQUIPMENT MAY CAUSE IMMEDIATE HAZARDS WHICH WILL LIKELY RESULT IN SERIOUS PERSONNEL INJURY OR DEATH.

WARNING

The equipment covered by this publication must be handled, installed, operated and maintained by qualified persons who have direct knowledge and experience dealing with the hazards involved and are thoroughly trained in the handling, installation, operation and maintenance of high voltage transmission and distribution equipment. These instructions are meant for only such **Qualified Persons**. They are not intended to be a substitute for adequate training and experience in safety procedures for this type of equipment.

A **Qualified Person** is one who is trained in and has skills necessary:

- to read and comprehend this instruction book – understanding that these instructions are general in nature
- to accept personal responsibility to prepare and maintain an intrinsically safe work environment and maintain control of the work site to safeguard all persons present
- to develop and implement a proper rigging, lifting, and installation plan along with all safety precautions required to insure safe and proper lifting and installation of the equipment.
- to distinguish between energized and non energized parts
- to determine proper approach distances to energized parts
- to properly work with and around energized or de-energized equipment that may be pressurized with gas
- for proper use of personal protective equipment, insulating and shielding materials, insulated tools for working near energized and /or pressurized electrical equipment
- to recognize and take necessary precautions for the unique and dynamic conditions of site and specialized equipment to maintain a safe work environment during handling, installation, operation, and maintenance of high voltage switching equipment

The instructions in this manual are general guidelines for this type of equipment and not specific to the equipment supplied. Portions of it may not be applicable or may not have complete instructions for your specific equipment.

If you do not understand any part of these instructions or need assistance, contact Southern States Service Division at 770-946-4562 during normal business hours (8:00am – 4:30pm EST, M-F) or 770-946-4565 after normal business hours.

The Quality Name in High Voltage Switching

LIMITED WARRANTY

Southern States, LLC (“SLLC”) warrants only to the Warranty Holder (hereinafter defined as the “End User” or the “Immediate Purchaser”, as applicable, pursuant to the terms and conditions of this Limited Warranty as set forth below), that the Product identified below will, upon shipment, be free of defects in workmanship and material for the applicable Warranty Period. The “Warranty Period” is that period of time during which this Limited Warranty is effective, and such period begins on the invoice date issued by SLLC for the Product, and continues until the earlier to occur of (1) the expiration of the Warranty Duration period, or (2) the Number of Operations, both as specified in the table below. If the Product is both purchased and installed within the United States or Canada, this Limited Warranty is granted to each end user of the Product who acquired the Product for its own use during the Warranty Period (“End User”). In all other situations, this Limited Warranty is granted only to the first purchaser of the Product (“Immediate Purchaser”) from SLLC. No primary or remote purchaser or owner of the Product who is not a Warranty Holder may claim any benefit under this Limited Warranty, or any remedial promise included in this Limited Warranty. SLLC shall, upon prompt written notice from the Warranty Holder, correct a nonconforming Product by repair or replacement at the sole discretion of SLLC of the nonconforming Product or any part or component of a nonconforming Product necessary in SLLC’s discretion to make such Product conforming. Any transportation charges, labor for removing, reinstalling the Product or part, and/or costs related to providing access to the Product shall be the responsibility of the Warranty Holder. Correction in this manner will constitute the Warranty Holder’s exclusive remedy and fulfillment of all SLLC’s liabilities and responsibilities hereunder. SLLC’s duty to perform under this limited warranty may be delayed, at SLLC’s sole option, until SLLC has been paid in full for all products purchased by the Warranty Holder. No such delay will extend the Warranty Period. If SLLC does not make such repair or replacement, SLLC’s liability for damages on account of any claimed nonconformity will in no event exceed the purchase price of the Product in question. This Limited Warranty does not apply to any Product that has been disassembled, repaired, or altered by anyone other than SLLC. This Limited Warranty will not apply to any Product that has been subjected to improper or abnormal use of the Product. SLLC has no responsibility to repair or replace any Product or component thereof manufactured by another party, but SLLC will assign, to the extent assignable, to the Warranty Holder any manufacturers’ warranty that applies to products and components not manufactured by SLLC.

THIS LIMITED WARRANTY IS EXCLUSIVE AND IN LIEU OF ALL OTHER WARRANTIES. THERE ARE NO OTHER EXPRESS, IMPLIED, OR STATUTORY WARRANTIES. ALL IMPLIED WARRANTIES WHICH MAY ARISE BY IMPLICATION OF LAW, OR APPLICATION OF COURSE OF DEALING OR USAGE OF TRADE, INCLUDING, BUT NOT LIMITED TO, IMPLIED WARRANTIES OF MERCHANTABILITY OR FITNESS FOR A PARTICULAR PURPOSE, NONINFRINGEMENT OR OTHERWISE ARE EXPRESSLY EXCLUDED. SLLC SHALL NOT BE LIABLE OR RESPONSIBLE FOR ANY CONSEQUENTIAL, INCIDENTAL, INDIRECT, EXEMPLARY, SPECIAL, OR PUNITIVE DAMAGES, EVEN IF SLLC HAS BEEN ADVISED OF THE POSSIBILITY OF SAME. THE WARRANTY HOLDER IS SOLELY RESPONSIBLE FOR THE SUITABILITY OF THE PRODUCT FOR ANY PARTICULAR APPLICATION.

Product Purchased Region	Product Installed Region	Warranty Holder	Warranty Duration
U.S and Canada	U.S and Canada	End User	Five (5) Years
All Other Conditions		Immediate Purchaser	Earlier of 1 year from installation or 18 months from shipment

Southern States, LLC**Equipment Receipt, Installation, Use, Operation and Maintenance Terms****(“Terms of Use”)**

The purchaser (“Purchaser”) of certain Equipment (the “Equipment”) identified in the Instruction Manual accompanying these Terms of Use sold by Southern States, LLC (“Southern States”), by Purchaser’s acceptance or Use of Equipment in any way, agrees to the Terms of Use set forth below (the word “Use” herein means receipt, testing, inspection, installation, operation, maintenance and otherwise handling the Equipment):

- Purchaser represents and warrants that it is fully qualified to Use the Equipment, and that it is a sophisticated user of the Equipment with a high level of expertise in the Use of the Equipment and Purchaser knows that Southern State is relying on Purchaser’s sophistication and expertise with respect to the Equipment.
- The Purchaser will, within seven (7) days after receipt of the Equipment, inspect the Equipment and identify and notify Southern States in writing of any missing parts, damage or defects observed in the Equipment.
- The Purchaser will Use the Equipment, only in conformity with all manuals, data sheets and instructions provided by Southern States, and in keeping with sound engineering, utility and safety practice. Purchaser will at its own expense, provide all necessary labor, supplies, and facilities required to Use the Equipment.
 - The Purchaser may use its own personnel or engage a third party to Use the Equipment. The Purchaser shall insure that it only utilizes personnel who are fully qualified or certified by a reputable certification agency to Use the Equipment. In the event that Purchaser cannot find such qualified personnel, the Purchaser will notify Southern States and seek its advice to determine a mutually agreeable solution.
 - By separate agreement, Southern States may provide such services and the personnel to conduct such services in connection with the installation of the Equipment. In the event Southern States agrees to provide personnel to install, maintain, and operate the Equipment, such personnel will function only in an advisory capacity and shall have no responsibility for the supervision, or the quality or workmanship of such installation, maintenance, or operate of the Equipment.
- The Purchaser shall not install and operate the Equipment in a way such that a single point of Equipment failure leads to a cascading event or consequential damage to any person or property. Purchaser shall ensure redundancy in its system at all times. Purchaser acknowledges and agrees that electric service is by nature subject to interruptions due to Equipment failures and shall not agree to provide service free from the effects of Equipment failures
- The Equipment will be maintained and inspected as provided by this instruction manual and in compliance with best industry practices, but in no event will the Equipment be inspected and tested less frequently than once in every 6 months.

The Quality Name in High Voltage Switching

- The Purchaser shall not repair, dismantle, or alter any of the Equipment without Southern States' written consent.
- Any failure of Equipment either in service, testing or inspection will be promptly reported in writing to Southern States within 24 hours of the failure so that adequate evidence can be collected, appropriate diagnostic tests can be conducted, and analysis of the failure can be determined.
- Southern States will have no liability for any direct, indirect, consequential or remote damage or injury, whether or not foreseen or foreseeable, to the Purchaser or any third party or person for any damages or injury to person or property caused by Purchaser's or any third party's actions, whether or not negligent, in the Use of the Equipment. Purchaser shall indemnify and hold Southern States and its employees, officers and directors against any damage or injury caused in whole or part by Purchaser's or any third party's action whether or not negligent, resulting from the Use of the Equipment. Southern States expressly rejects any liability to third parties. The Purchaser expressly waives any claim against Southern States, its employees, officers, directors and affiliates, for injury or damage to person or property resulting from Use of the Equipment not directly and solely caused by Southern States' negligence. For the purposes of clarity, Southern States shall not be liable, and be fully indemnified by the Purchaser, for the following related to the Equipment: normal wear and tear, excessive use and loading, improper interference or maintenance on the part of the Purchaser or third parties, incomplete or false information given by the Purchaser, inappropriate or improper Use, faulty operation, installation or start-up, faulty or careless handling, improper maintenance, use of unsuitable operating materials/substitute materials, defective construction work, hazardous ambient conditions unknown to the Purchaser, chemical, electro-chemical or electrical influences, changes to the subject of delivery made without Southern States consent.
- In the event that Southern States is found by a court of competent jurisdiction or a properly empaneled arbitral body to be liable to the Purchaser for any reason, Southern States shall be entitled to a reduction in the liability by taking into account the exceptions provided by statute, law, and any counterclaims Southern States may have against Purchaser.
- The failure of Purchaser to comply with these Terms of Use herein shall void any and all warranties related to the Equipment. These Terms of Use shall be deemed to be part of the binding contractual agreements between Purchaser and Southern States related to the Equipment and shall govern over any inconsistent term or provision in such other contractual agreements.

Type EV-2H
Aluminum Vertical Break Disconnect Switch
up to 245 kV



Table of Contents

Table of Contents	VIII
List of Tables and Figures	IX
Summary & Introduction	1
Summary	1
Important	1
Introduction	2
Recommended Tools & Values	3
Product Description	4
Typical Disconnect Switch	4
Receiving, Handling, & Storage	5
Receiving & Unpacking	5
Storage	5
Installation & Adjustment Procedures	6
Assembly	6
1. Preferred Switch Assembly Method	6
2. Contact Adjustment	8
3. Mounting disconnect switch onto the structure	10
4. Optional Accessories	10
5. Operating Mechanism	13
6. Switch Adjustments (Tuning)	15
Recommended Inspection Maintenance	Error! Bookmark not defined.
Patrolling Inspection (6 Months)	Error! Bookmark not defined.
Routine Inspection & Maintenance (5 year)	Error! Bookmark not defined.
Periodic Inspection & Maintenance (10 year)	Error! Bookmark not defined.

The Quality Name in High Voltage Switching

List of Tables and Figures

Tables **Page**

Table 1: Recommended Tools and Torque Values	3
Table 2: Recommended Installation and Maintenance Table	19

Figures **Page**

Figure 1: Typical EV-2H disconnect switch & Common Terminology	4
Figure 2: Match-Marked Components	6
Figure 3: Insulator Stack Alignment	7
Figure 4. Contact blade centered among contact fingers	8
Figure 5. Evenly Distributed Contact at All Points, On Both Sides	8
Figure 6. Blade Tip Travel.....	9
Figure 7. Blade Tip Must Be As Flat in the Jaw as Possible	9
Figure 8: Arcing Horn Attachment.....	10
Figure 9: Sling Attachment.....	11
Figure 10: Proper Mounting Positions.....	11
Figure 11: BLADE STOP (OPEN POSITION)	12
Figure 12: Insulator Stack Adjustment for Various Mounting Positions.....	12
Figure 13: Typical Operating Mechanism for EV-2H	13
Figure 14: Alternate Operating Mechanism Designs	13
Figure 15: Typical Operating Arrangement.....	14
Figure 16: Type HOGO (High Output Geared Operator) Front View	15
Figure 17: Type SEGO (Safety Enhanced Gear Operator)	16
Figure 18: Switch – Fully Closed Position	17
Figure 19: Adjustable Arm Assembly.....	18

Summary & Introduction

Summary & Introduction

Summary

These instructions do not intend to cover all details or variations in equipment, or provide for every possible contingency to be met in connection with installation, operation or maintenance. Should information be desired or should particular problems arise which are not covered sufficiently for the purchaser's purposes, the matter should be referred to the local Southern States Representative.

The contents of this instruction manual should not become part of or modify any prior or existing agreement, commitment or relationship. The sales contract contains the entire obligations of Southern States. The Warranty contained in the contract between the parties is the sole warranty of Southern States. Any statements contained herein do not create new warranties or modify the existing warranty.

Important

The information contained herein is general in nature and not intended for specific application purposes. It does not relieve the user of responsibility to use sound practices in application, installation, operation, and maintenance of the equipment purchased. Southern States reserves the right to make changes in the specifications shown herein or to make improvements at any time without notice or obligations. Should a conflict arise between the general information contained in this publication and the contents of drawings or supplementary material, or both, the latter shall take precedence.

Summary & Introduction

Introduction

The Southern States type EV-2H is a three phase, group operated, vertical break air disconnect switch. Poles can be mounted in a horizontal “upright”, vertical, or under hung position. The switch may be operated using a manual operator or electrical motor operator.

The installation procedure for all mounting positions and operating schemes are similar and explained herein. A system of pipes, bearing, and adjustable length arms are utilized to open and close the switch from a ground level operator.

The installation procedure for all mounting positions and operating schemes is similar and explained herein. A system of pipes, bearing, and adjustable length arms is utilized to open and close the switch from a ground level operator.

The instructions contained within this manual are necessary for the safe installation, maintenance, and operation of the EV-2H switch. A qualified person, familiar with this of type equipment, should carefully read and follow the instructions.

These instructions are intended to provide a general guideline for the installation, adjustment, and maintenance of the EV-2H switch. It is not possible to cover all details, equipment variations, and potential conditions. Contact Southern States, LLC in the event conditions associated with a specific application are not sufficiently addressed.

All photographs and sketches in this manual are for illustration purposes only and may not be to scale. Refer to the Unit Assembly drawing or the Operating Mechanism drawing provided with each disconnect switch for specific details. During installation, it may be necessary to make adjustments other than those described in this manual. Contact your local representative or the factory if questions should arise.

Southern States After Sales and Service Department is available for field installation assistance along with providing parts support for all Southern States products.

Contact After Sales and Service at 770-946-4562, 7:30am-4:00pm EST Monday-Friday.
After Hours: 770-946-4565

Distinctive signal words are used to indicate the degree of hazard that may be encountered by the user. Identification of the signal words and their definition follow:

 DANGER	Indicates an imminently hazardous situation, which, if not avoided, will result in death or serious injury.
---	---

 CAUTION	Indicates a potentially hazardous situation, which, if not avoided, may result in minor or moderate injury. It may also be used to alert against unsafe practices.
--	--

 WARNING	Indicates a potentially hazardous situation, which, if not avoided, could result in death or serious injury.
--	--

Summary & Introduction

Recommended Tools & Values

Table 1: Recommended Tools and Torque Values

Recommended Tools		Recommended Torque Values	
Type	Sizes	Bolt/Nut size	Torque (Ft-lb)
Hand Wrenches and/or Sockets	15/16", 3/4", 5/8", 9/16"	1/2"	40
Drill Bit	1/4"	5/8"	92
Slotted Screwdriver		3/4"	127
SAE Hex Key Set		1"	286

Product Description

Typical Disconnect Switch

In general, installing a disconnect switch consists of the following:

- Mounting the insulators to the switch base
- Mounting the live parts to the insulators
- Mounting the switch base to the structure
- Installing operating components
- Final adjustment or tuning is then completed.

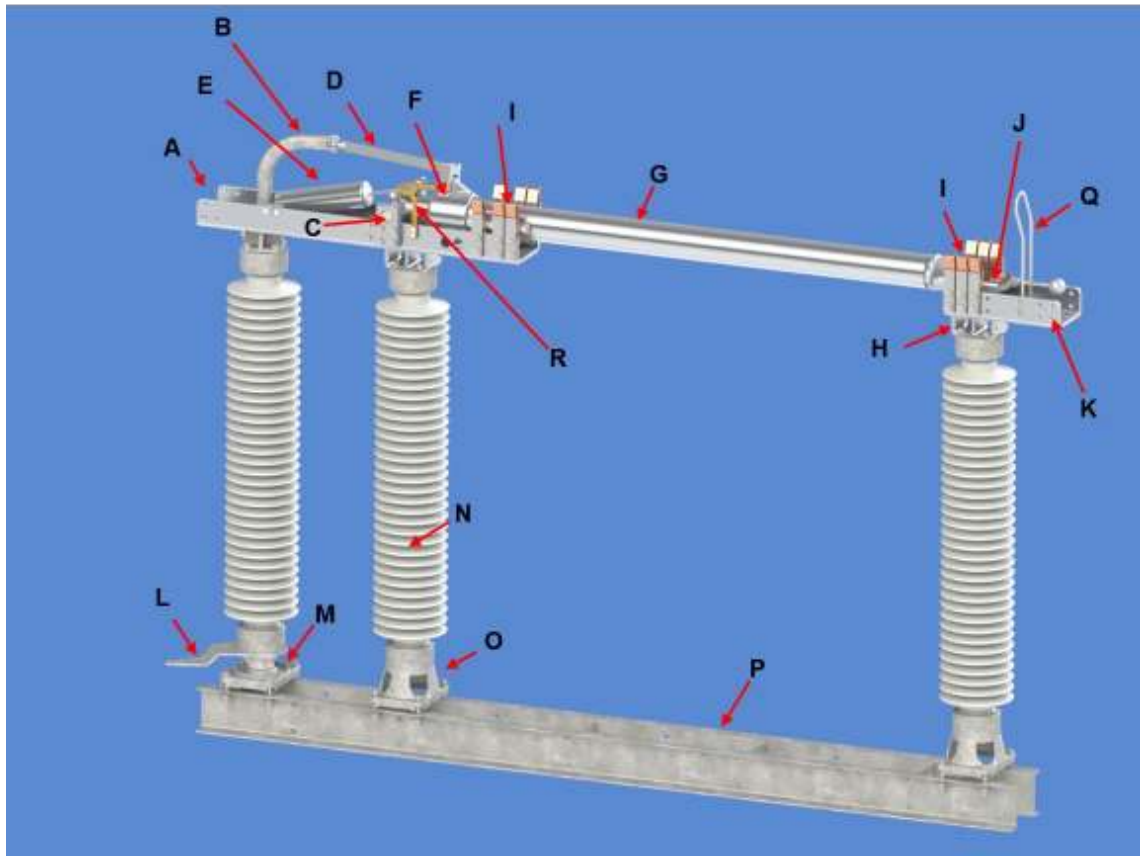

A – Terminal Pad Assembly	G – Blade	M – Bearing
B – Crank Arm	H – Insulator Adapter	N – Insulator
C – Blade Carrier Adapter	I – Contact Fingers	O – Insulator
D – Yoke	J – Contact Bar	P – Base
E – Counter Balance	K – Terminal Pad	Q – Arcing Horn
F – Blade Socket	L – Switch Operating Arm	R – Braided Connector

Figure 1: Typical EV-2H disconnect switch & Common Terminology

Receiving, Handling, & Storage

Receiving, Handling, & Storage

Receiving & Unpacking

Unpack the equipment and check for damages or shortages immediately. The bill-of-material from the Unit Assembly (switch) and Operating Mechanism drawings should be used for this purpose. If damage or a shortage is noted, file a claim immediately with the carrier and contact the factory.

Storage

All components of the EV-2H vertical break disconnect switch are suitable for outdoor use and do not have any special storage requirements. If a motor operator is furnished be sure to connect the heater circuit, using the provided external wiring, while the unit is in storage. Discard the wiring upon installation.

Typical crating is intended for storage less than 1 year. If long term storage is required please notify factory at time of order placement so that special crating can be used.

Installation & Adjustment Procedures

Installation & Adjustment Procedures

Assembly

1. Preferred Switch Assembly Method

- 1.1. **If Disconnect switch is shipped assembled on insulators Skip Section 1 and Continue to Section 2.**
- 1.2. Switches rated 72.5 KV and above are normally shipped assembled separately from their insulators, with the live parts of each unit bolted to their own base. Installation consists of removing the live parts from the base, mounting the base on the structure, the insulators to the base, and the live parts to the insulators.
 - 1.2.1. Alternately (and easier) each pole may be assembled on the ground and hoisted to the structure as a complete unit. **CAUTION:** To prevent overturning during assembly, the switch base must be bolted to a level, stable platform (e.g. metal sawhorses). **CAUTION:** Lift fully assembled pole unit by the base only. **DO NOT** lift the pole unit by the live parts. Refer to **Figure 1** and **Figure 9**.
- 1.3. Before disassembling the live parts from the switch base you must match mark the insulator bearing hub, switch arm, and rotating base to ensure correct reassembly (**See Figure 2**). Match-mark A to B and B to C. Failure to complete this step will make final adjustment more difficult.
- 1.4. **OPEN THE SWITCH** and remove the switch live parts. Place them in a safe place to avoid damage. (Vertical and underhung mounted switches should be opened only far enough to relieve the contact pressure on the switch blade prior to removal of the live parts.)
- 1.5. Refer to the Unit Assembly and Field Assembly (SF) Drawings for bolt sizes. Mount the insulators to the base adapters and the switch arm plate on the bearing. Confirm match marks are aligned and properly torque the bolts (see **Table 1** on page 3).
- 1.6. Confirm proper insulator alignment, the rotating insulator must be as near to perpendicular as possible to both the long and short axis of the disconnect switch base. **NOTE:** The original insulator stack height must be maintained. When the nuts on the jack bolts are used to adjust insulator tilt, opposite nuts must be turned equally (run one nut up a certain number of turns, turn the opposite nut down the same number of turns).

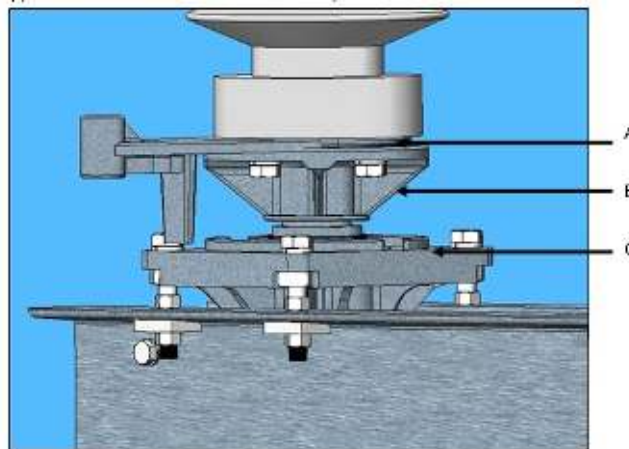

Figure 2: Match-Marked Components

A = Interpole Arm, B = Bearing Hub, C = Bearing Housing

Installation & Adjustment Procedures

- 1.6.1. Always be sure to tighten the bottom hex nuts securely after jackscrew adjustments are complete (**Figure 3**).
- 1.6.2. After making sure that the rotating insulator is perpendicular to the base, use the jackscrews on the rigid hinge insulator to line up the mounting holes (do not force the parts), and bolt the hinge assembly into position.
- 1.6.3. Once the hinge insulators are aligned, do not readjust them. Any contact alignment adjustments will be made to the jackscrews that support the jaw insulator.
- 1.6.4. Mount the jaw contact assembly to the insulator and, for the moment, leave the bolts loose. Close the switch blade into the contacts, checking for alignment as shown in **Figure 4** and **Figure 5**. Usually bolt hole tolerances will be sufficient to align the contacts properly. However, the jackscrews that support the jaw insulator stack can also be used to tilt the insulator as required.
- 1.6.5. Most importantly, however, final contact adjustment and inspection can be made only after the conductors are attached to both ends of the switch pole. This is because the weight of long conductors can deflect insulators sufficiently to cause contact misalignment. **MAKE FINAL CONTACT ADJUSTMENT ONLY AFTER CONDUCTOR ATTACHMENT.**

How to adjust Alignment:

- **Caution:** Do not turn stud!
- Loosen all four "A" nuts.
- Tilt insulator to necessary angle using "B" nuts.
- Adjust all four "B" nuts (up or down) until proper alignment is achieved.
- Retighten nuts to proper torque.

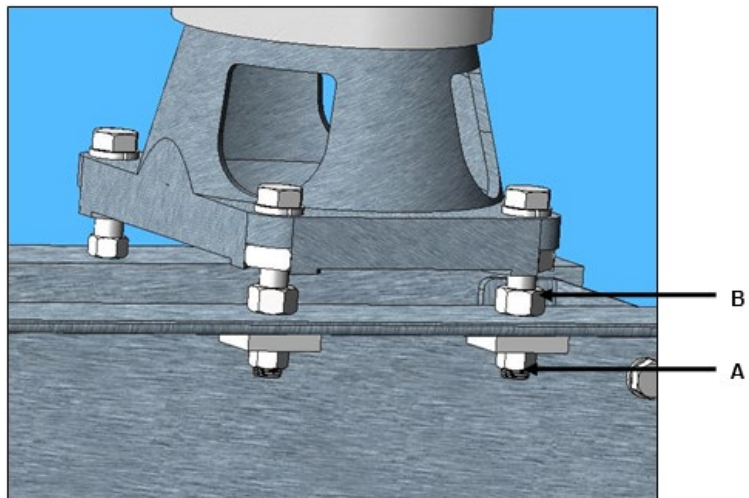

Figure 3: Insulator Stack Alignment

- 1.6.1. Confirm that switch is oriented properly, per the unit assembly drawing.
- 1.6.2. Confirm that the match marks are aligned and all hardware is tight.

Installation & Adjustment Procedures

2. Contact Adjustment

- 2.1. There are five conditions that determine proper contact adjustment. All conditions must be checked after conductor attachment to both ends of the switch pole
 - 2.1.1. The jaw contact leaves (fingers) must be centered on the silver of the blade tip as shown in **Figure 4**. If necessary, use the jack screws that support the jaw insulator to tilt the insulator fore or aft to align these parts.

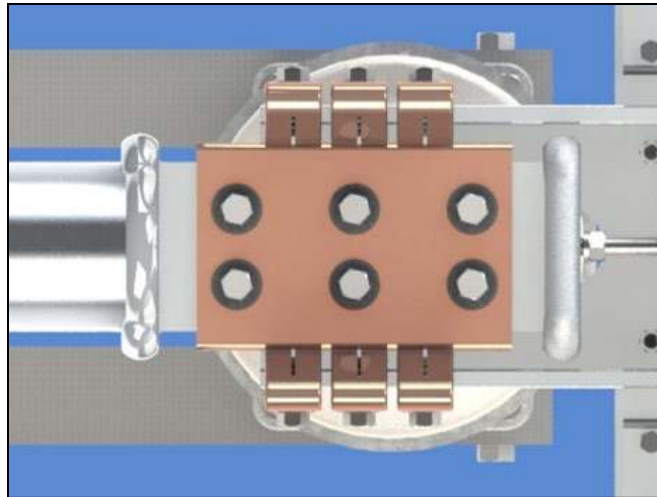

Figure 4. Contact blade centered among contact fingers.

- 2.1.2. All contact leaves (fingers) must be in contact with the silver of the blade tip as shown in **Figure 5**. If necessary, shift the jaw against the bolt hole tolerances as required to achieve full contact distribution along the length of the blade tip.

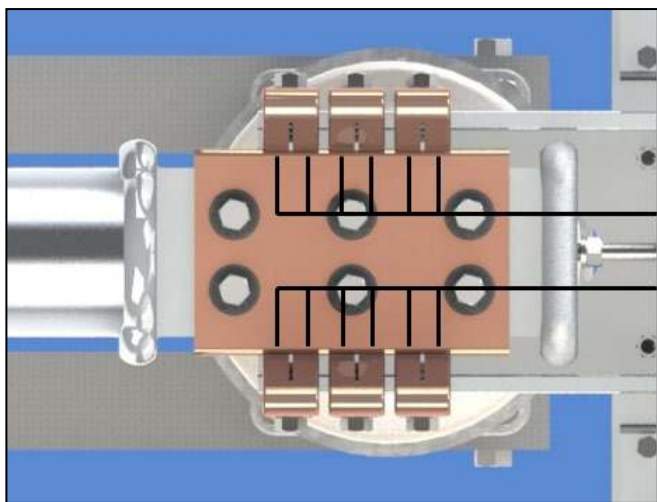

Figure 5. Evenly Distributed Contact at All Points, On Both Sides

Installation & Adjustment Procedures

- 2.1.3. The blade tip must come down into the jaw in its center, without dragging on either side as shown in **Figure 6**. Use the jack screws that support the jaw insulator to tilt the insulator sideways, if necessary to ensure this condition.



Figure 6. Blade Tip Travel

- 2.1.4. The blade tip must come down firmly on the stop in the jaw. If necessary, use the jack screws that support the jaw insulator to elevate it as required. Note: By adjusting all jackscrews equally (count the flats) and previous adjustment will not be disturbed.

⚠ CAUTION Never attempt to force the blade tip into the jaw. Any attempt to adjust the contact / blade tip alignment by bending the blade will result in damage to the switch which will prevent further operation.

- 2.1.5. These switches will have adequate contact pressure if the blade has rotated to within plus or minus 5° of perpendicular in the contacts as shown in **Figure 7**. Adjustment of the bearing stop may be required.

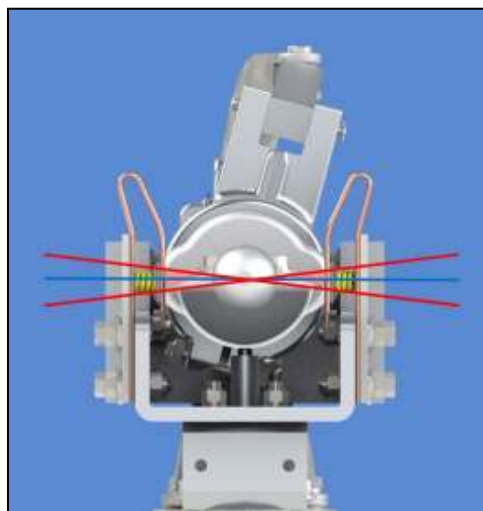

Figure 7. Blade Tip Must Be As Flat in the Jaw as Possible
Refer To Unit Assembly Drawing For Closed Position Stop Location

Installation & Adjustment Procedures

- 2.1.6. **ENERGIZE THE SWITCH ONLY AFTER A FINAL INSPECTION OF ALL FIVE OF THESE CONDITIONS FOR PROPER CONTACT.**

3. Optional Accessories

3.1. Arcing Horns (if equipped):

- 3.1.1. Refer to the Unit Assembly drawing for necessary hardware and installation location.
- 3.1.2. Arcing horns should rub lightly together with sufficient pressure to maintain contact, but not to cause binding.
- 3.1.3. Arcing horns should be touching when the switch is fully closed as shown in **Figure 8**. If necessary the jaw (stationary) arcing horn may be bent to achieve proper contact.

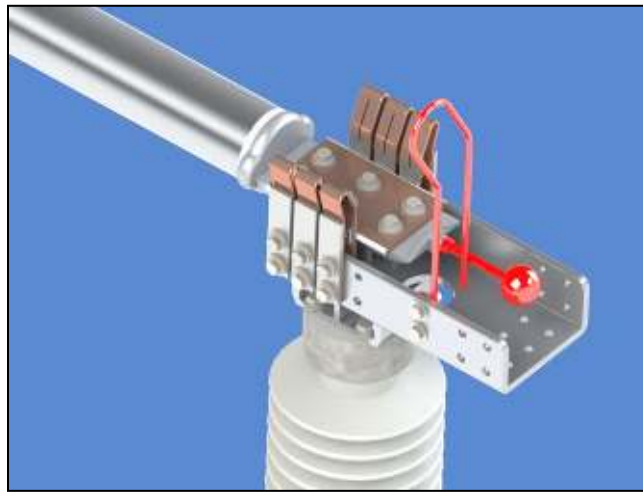

Figure 8: Arcing Horn Attachment

4. Mounting disconnect switch onto the structure

- 4.1. If the switch has been assembled on the ground, at this time mount it on the structure. Check the Operating Mechanism Drawing for proper position. **LIFT THE SWITCH BY THE BASE ONLY.**
- 4.2. With the switch closed, secure the blade using rope or other type of strap, to avoid movement during lifting.
- 4.3. Secure the switch arm to the bearing stop using a wire or strap prior to lifting.
- 4.4. Lift the assembled switch by the switch base only. Refer to **Figure 9**.

Installation & Adjustment Procedures

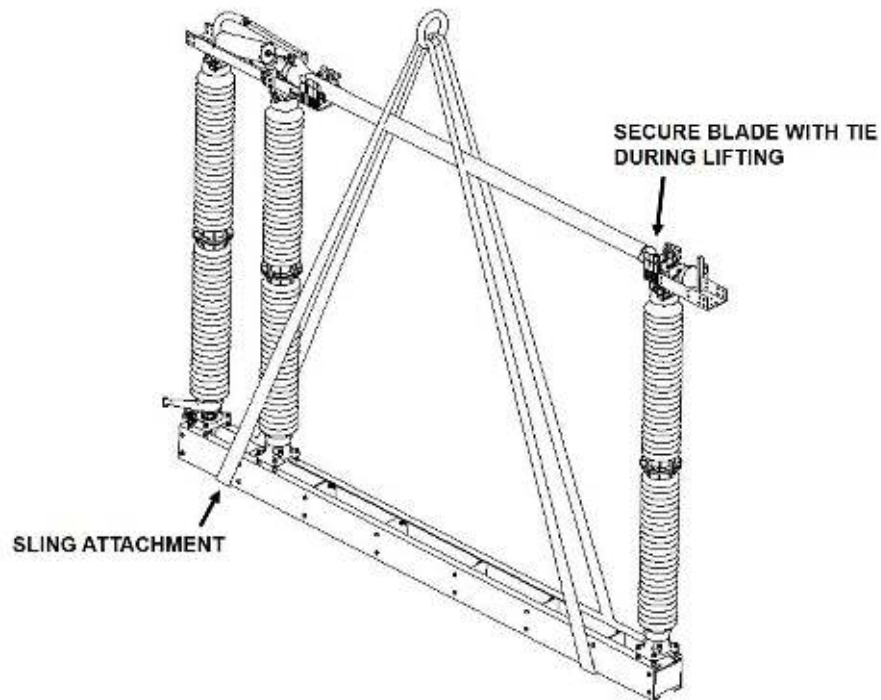

Figure 9: Sling Attachment

- 4.5. Mount the disconnect switch to the structure using the hardware indicated by the Operating Mechanism drawing (see **Table 1** for torque spec).
- 4.6. The Mounting Positions and Proper Blade Openings are shown in **Figure 10**.

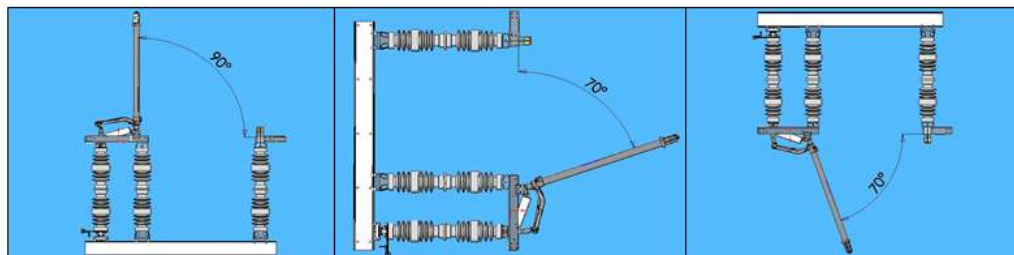

Figure 10: Proper Mounting Positions

- 4.6.1. Conventional blade open positions are shown in **Figure 10**. The EV-2H switch will be shipped with one of these blade open angles unless another angle is specified. Slight changes to the blade fully open angles are easily made in the field. Simply adjust the open position stop bolt on the blade carrier assembly shown in **Figure 11**, and then readjust the stop located at the bottom of the rotating insulator to match the blade angle.

Installation & Adjustment Procedures

- 4.7. GENERAL INSTALLATION NOTE: Live part stops (the blade open and closed position stop bolts located on the parts above the insulators) are correctly engaged when touching lightly. The over travel bearing stops at the bottom of the insulator are correctly adjusted when there is a 1/16" to 1/8" clearance between the stop and the stop bolt.

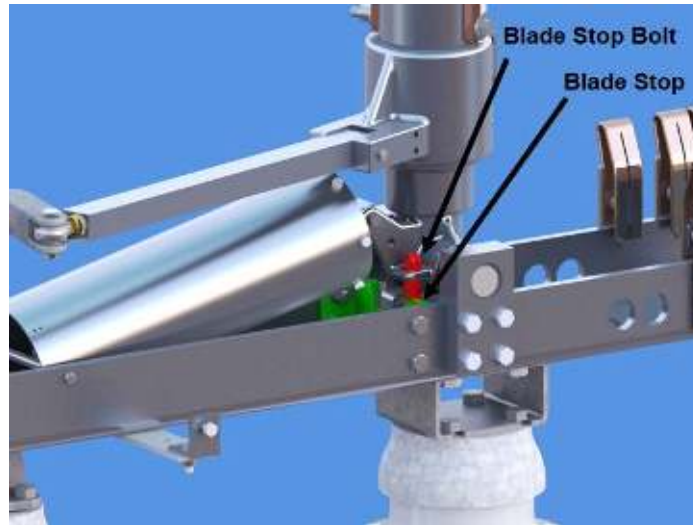

Figure 11: BLADE STOP (OPEN POSITION)

- 4.8. **If possible** mount the conductors to both ends of the switch pole before adjusting switches.
- 4.9. Conductor loads can alter fine switch adjustments, so final adjustments should not be performed prior to connecting the conductors
- 4.10. Verify that the insulators are still properly aligned.
- 4.10.1. Refer to **Figure 3** and **Figure 12**. Adjust both "A" nuts and "B" nuts equally to correct any misalignment.
- 4.10.2. After adjustment, torque the nuts properly (see **Table 1**).

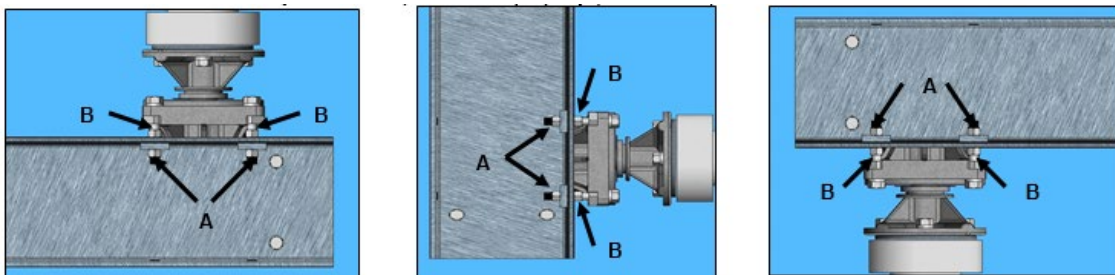

Figure 12: Insulator Stack Adjustment for Various Mounting Positions

Installation & Adjustment Procedures

5. Operating Mechanism

- 5.1. These switches are designed to be opened and closed as a three-phase unit by a system of pipes that translates the rotational movement of an operator on the ground (whether manual or motor) to simultaneous rotation of the end insulator of each switch pole.
- 5.2. **Figure 13** shows a typical operating mechanism for a 145kV vertical break switch. **Figure 14** shows alternate operating mechanism designs, each of which is employed as being the simplest arrangement for a given structure. In all cases, however, the operating principle remains the same, and the methods of installation and adjustment are virtually identical.

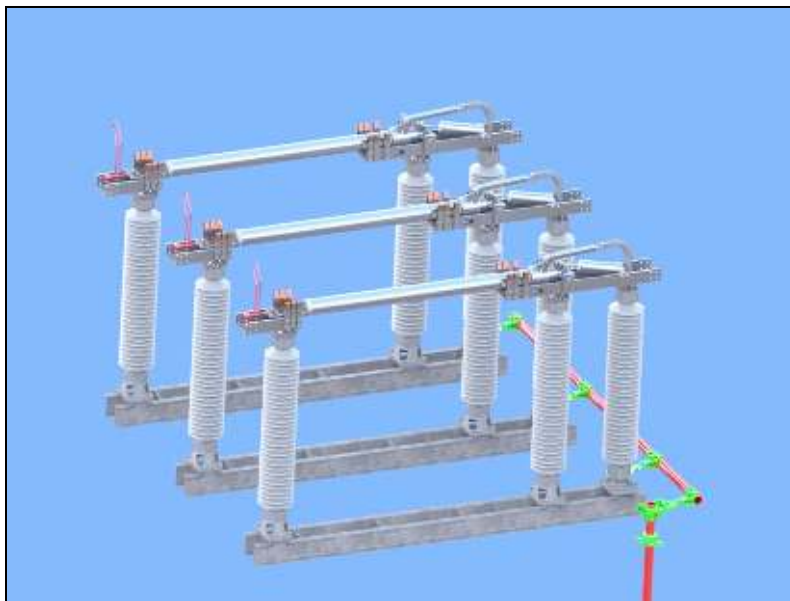

Figure 13: Typical Operating Mechanism for EV-2H

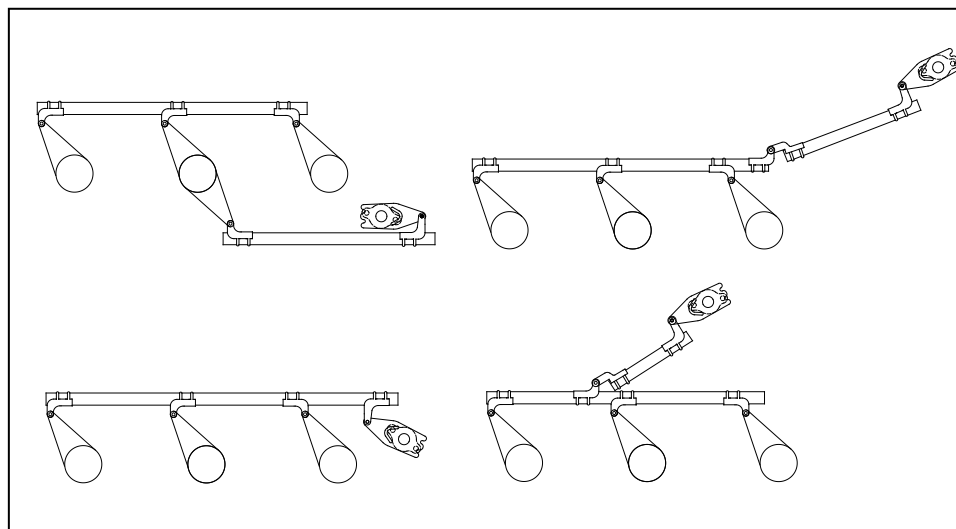

Figure 14: Alternate Operating Mechanism Designs

Installation & Adjustment Procedures

- 5.3. Lay out all the operating mechanism parts and check them against the Operating Mechanism drawing bill-of-material.
- 5.4. To aid switch inspection from the ground, there will be at least one threader bolt (piercing bolt) on every Operating Mechanism. They may be installed, in most cases, on the bottom sides of the clevises so they can be viewed from the ground when pinned. **Do not pierce pipe at this time.**
- 5.5. To ensure that the bearing stops do not interfere with switch adjustments, loosen each open/close bearing stop and slide them out of the way.
- 5.6. Refer to the Operating Mechanism drawing and install all mounting brackets, bearings, bushings, pipe clevises, switch operating device, adjustable arm, reach rod, and other necessary components. Refer to **Figure 15**. Do not connect the interphase pipe at this time.

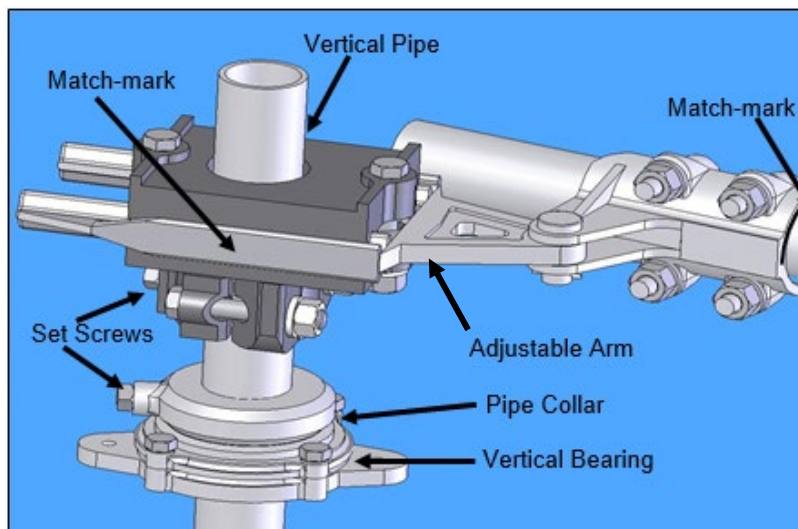

Figure 15: Typical Operating Arrangement

- 5.7. **CAUTION:** The pipe collar (above the vertical bearing support) must support the entire weight of the vertical operating pipe. **Do not allow the pipe to rest on the switch operating device.** Refer to **Figure 16 & Figure 17**.
- 5.8. When a switch uses an auxiliary switch arm, installation will be easier if this pole is adjusted **before** installing the interphase pipe. This will eliminate trying to coordinate and adjust all three poles at once. Refer to Op-Mech drawing for auxiliary arm mounting degree.
- 5.9. While installing the pipes and clevises that have threader bolts (piercing bolts), **do not** pierce the pipe until instructed.
- 5.10. After mounting all the operating mechanism components, match-mark all clevis connections, the adjustable arm, and the switch operating device's coupling, so that you can tell if slippage occurs during trial operations.

Installation & Adjustment Procedures

6. Switch Adjustments (Tuning)

- 6.1. The operating mechanism is intended to fully open and fully close the disconnect switch by rotating the vertical operating pipe 180°± using an operator (manual or electrical). The interphase pipe controls the individual operation of each switch pole, using a push/pull control. The reach rod translates the motion of the vertical operating pipe to the interphase linkage. The adjustable arm (**Figure 15**) controls the total amount of switch operation available.

HINT: For easiest adjustment start with the reach rod connected to the drive phase and the interphase pipe disconnected from the other two phases. Once the drive phase is properly adjusted, connect the interphase pipe and continue tuning the other two phases. Care should be taken to ensure that the operating mechanism only exerts enough force to toggle the blade tip perpendicular to the jaw contacts. Excess downward force on the blade could result in damage to the switch that will render it inoperable.

6.2. Switch Operating Devices:

6.2.1. Worm gear operator (HOGO – High Output Geared Operator)

- 6.2.1.1. The operator handle is factory set to rotate either clockwise or counter-clockwise to open the switch.
- 6.2.1.2. When the switch is properly adjusted the operator handle should hang vertically and free in both the open and closed positions to permit the use of a customer supplied padlock. Refer to **Figure 16**

CAUTION Be aware that there is an adjustable stop on the operator. **Do not over operate as damage will occur to the operator.**

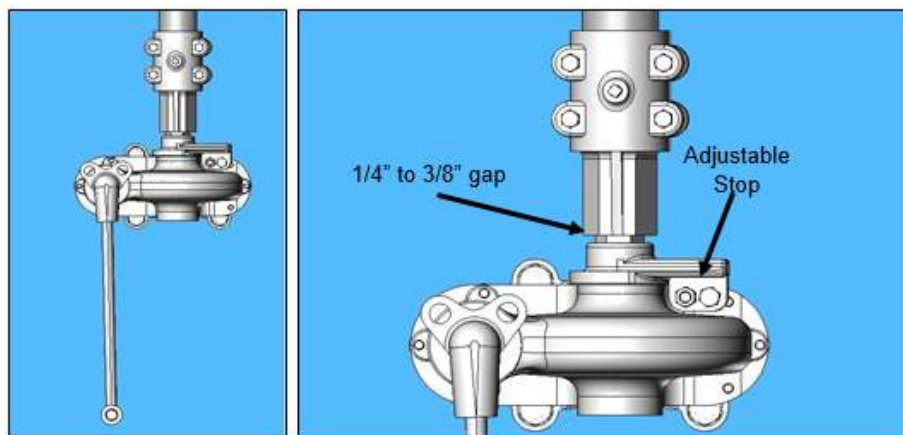

Figure 16: Type HOGO (High Output Geared Operator) Front View

Installation & Adjustment Procedures

- 6.2.2. Worm gear operator (SEGO – Safety Enhanced Gear Operator) (Optional)
 - 6.2.2.1. The weight of the vertical operating pipe should be supported by pipe collar by maintaining the 1/4"-3/8" gap.
 - 6.2.2.2. When the switch is properly adjusted the operator handle should hang freely in both the open and closed positions to permit the use of the customer supplied padlock.

▲ CAUTION Be aware that there is an adjustable stop on the operator. **Do not over operate as damage will occur to the operator.**

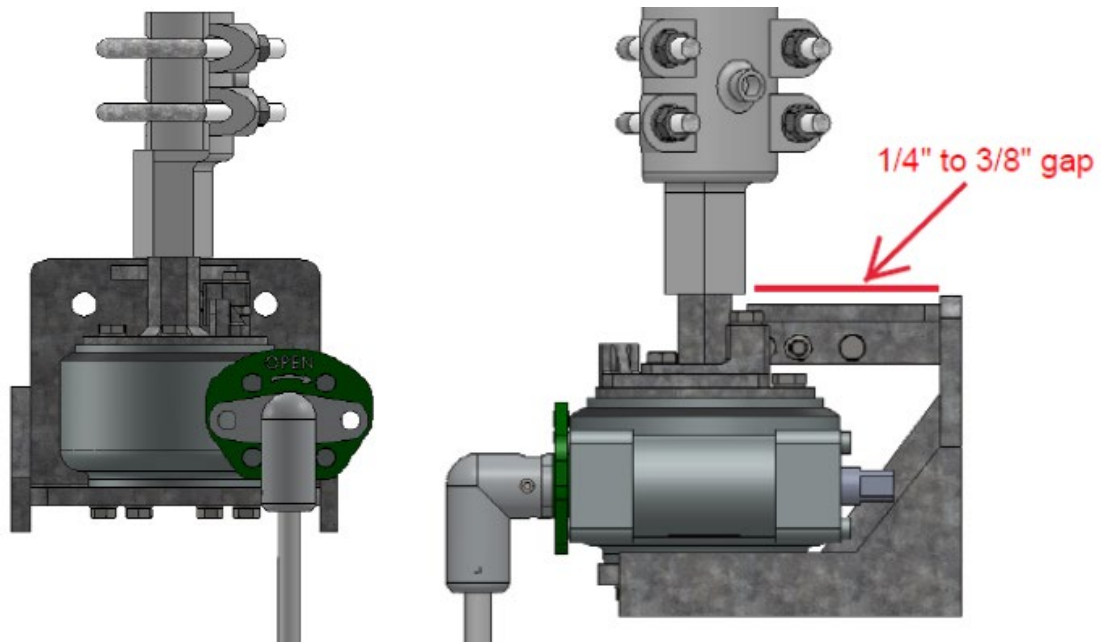

Figure 17: Type SEGO (Safety Enhanced Gear Operator)

- 6.2.3. Swing handle operator
 - 6.2.3.1. Adjust stops on handle mount after adjusting switch.
 - 6.2.3.2. When the switch is properly adjusted the handle should hang vertically and free in both the open and closed positions to permit the use of a customer supplied padlock.
- 6.2.4. Electrical motor operator
 - 6.2.4.1. Please refer to motor operator instruction manual for proper installation and setup.
 - 6.2.4.2. Use manual operation while completing switch setup.

Installation & Adjustment Procedures

- 6.2.4.3. **Do not** electrically operate until all switch adjustments are complete. **ALWAYS** operate the motor operator decoupled first to ensure proper setup.
- 6.3. Preliminary Switch Settings:
- 6.3.1. Start with the disconnect switch and operating mechanism in the closed position. Refer to **Figure 18**
 - 6.3.2. Set the adjustable arm to the preliminary setting specified on the Operating Mechanism drawing, adjustment may be necessary to achieve proper operation.
 - 6.3.3. Be sure that all the lower bearing stops have been loosened to prevent binding during test operations.

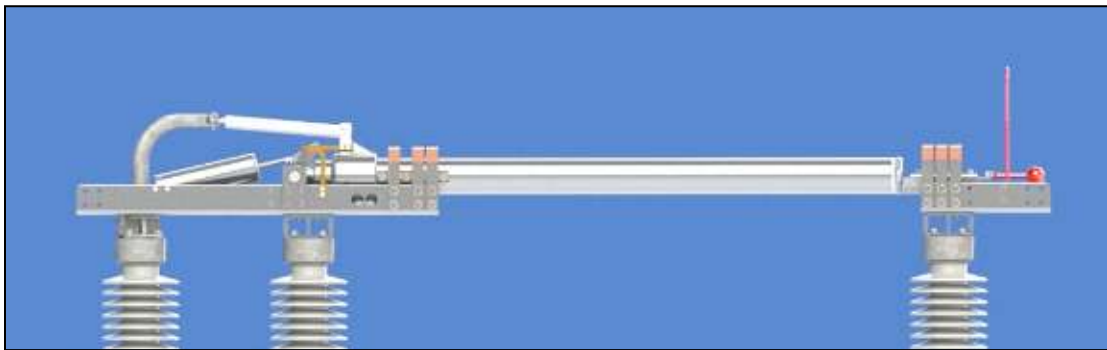

Figure 18: Switch – Fully Closed Position

- 6.4. Final Adjustment:
- 6.4.1. Before piercing any pipes, always check that none of the clamped joints have slipped. If slippage occurs, correct it and repeat the operation to verify that adjustment is good.
 - 6.4.2. Open the disconnect switch with the operator.
 - 6.4.3. If the switch is not fully open before the operator reaches the fully open position, the adjustable arm radius is too short. To correct:
 - 6.4.3.1. Check to see that nothing has slipped.
 - 6.4.3.2. Return the switch to **almost** the closed position, but not toggled.
 - 6.4.3.3. Match-mark the adjustable arm and the pipe clevis
 - 6.4.3.4. Loosen the bolts on the adjustable arm and pipe clevis
 - 6.4.3.5. Lengthen the adjustable radius arm approximately $\frac{1}{4}$ inch. Allow the pipe clevis to reposition itself the same $\frac{1}{4}$ inch. Refer to **Figure 19**.
 - 6.4.3.6. Tighten bolts and test operate - readjust as necessary.

Installation & Adjustment Procedures

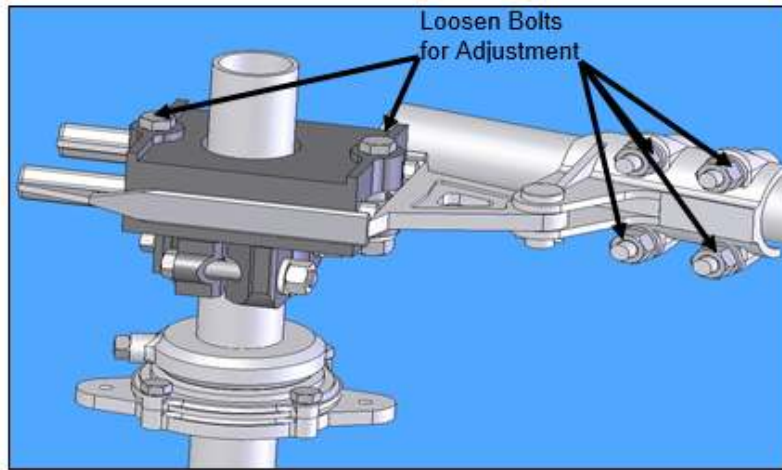

Figure 19: Adjustable Arm Assembly

- 6.4.4. If the switch is fully open before the operator reaches the fully open position, the adjustable arm radius is too long. To correct:
 - 6.4.4.1. Check to see that nothing has slipped.
 - 6.4.4.2. Return the switch to **almost** the closed position, but not toggled.
 - 6.4.4.3. Match-mark the adjustable arm and the pipe clevis
 - 6.4.4.4. Loosen the bolts on the adjustable arm and pipe clevis
 - 6.4.4.5. Shorten the adjustable radius arm approximately $\frac{1}{4}$ -inch. Allow the pipe clevis to reposition itself the same $\frac{1}{4}$ inch. Refer to **Figure 19**.
 - 6.4.4.6. Tighten bolts and test operate - readjust as necessary.
- 6.4.5. All poles of the fully adjusted disconnect switch should operate together although a slight variance between poles is acceptable. The primary objective is for all poles to fully open and fully close. Minor adjustments of the interphase pipe clevises may be necessary for pole coordination.
- 6.5. Final Check:
 - 6.5.1. Once all final adjustments are complete, be sure that all nuts are tightened to their specified torque (refer to **Table 1** on page 3).
 - 6.5.2. Tighten piercing bolt until it pierces the pipe wall. For heavy walled pipe, (schedule 80 or above, 3 inch or above) pre-drill the threader bolt (piercing screw) holes with a threader drill guide (provided) and a $\frac{1}{4}$ inch drill bit. Tighten until there is pressure. Do not tighten bolt the entire length of the bolt.

Recommended Inspection Maintenance

Recommended Inspection Maintenance

Southern States' disconnect switches are designed to operate with minimum maintenance. While disconnecting switches are not readily serviced at frequent intervals, *periodic inspection is important for satisfactory operation and maximized overall life*. Frequency of inspection and maintenance depends on the installation site, weather, atmospheric conditions, experience of operating personnel, and any special operation requirements.

During operational testing, the switch should be opened and closed several times, if possible, to clean the contacts and free the moving parts. A visual inspection, when the switch is wet, or temperature scanning detector may indicate hot spots that could serve as potential sources of trouble. Directional microphones or ultrasonic detectors can be used to locate local corona sources on the switches which can be eliminated during normal switch maintenance.

NOTE

It is recommended that maintenance on these switches be performed in accordance with ANSI STANDARDS **C37.30.1-2011**. In addition, well-established live-line servicing and maintenance procedures may be used in accordance with user practices and local and OSHA regulations.

Table 2: Recommended Installation and Maintenance Table

		Installation Tests	Patrolling Inspection 6-months	Routine 5 Year *	Periodic 10 Year *
Insulators	Contamination	X	X	X	X
	Damage	X	X	X	X
Cabinet (if motor operator supplied)	Any loose parts on the floor of the cabinet?	X	X	X	X
	Wiring Secure	X	X	X	X
	Links Secure	X	X	X	X
	Inspect Mechanism for loose parts	X	X	X	X
	Heaters Energized	X	X	X	X
	Door Seal	X	X	X	X
	Mechanical	Operational Tests	X		X
Electrical	Contact Resistance	X		X	X
Liveparts Inspection	Inspect Contacts	X		X	X
	Inspect Arcing Horns	X		X	X

***NOTE:** Inspection/maintenance is suggested to be performed every two (2) years when installed in harsh environments with excessive airborne contaminants such as salt spray and industrial pollutants.

Recommended Inspection Maintenance

Patrolling Inspection (6 Months)

The patrolling inspection is a largely visual inspection on an energized unit in service. The frequency of the inspection is determined by the local conditions and policies of the owner of the equipment.

- Inspect the insulators for breaks, cracks, burns, or cement deterioration. Clean insulators particularly where abnormal conditions such as salt deposits, cement dust, or acid fumes exist to minimize possibility of a flashover.
- If an accompanying motor operator is supplied, check the cabinet for loose parts and ensure that all wiring is secure, the heater is energized, and the door is sealed.

Routine Inspection and Maintenance (5 year)



The disconnect switch must be de-energized, disconnecting from all electrical power sources before servicing.

- Perform patrolling inspection (above), checking insulators and cabinet
- Once the disconnect switch is de-energized, test operate the switch multiple times.
- Check the switch for alignment, contact pressure, eroded contacts, corrosion, and mechanical malfunction, replacing damaged or eroded components if necessary. If contact pitting is minor, smooth the surface with a clean, fine sandpaper. It is recommended to clean and reapply C5-A grease during any operation or maintenance cycle, as exposed surfaces (*such as contacts*) are vulnerable to environmental conditions and contaminants that can decrease the effectiveness of the grease over time. During reapplication, clean and wipe down the contact surfaces with a green Scotchbrite pad, reapply C5-A grease, and remove any excess grease until an evenly coated, thin film is present.
- Inspect arcing horns for signs of excessive arc damage and replace if necessary.
- Check blade lock or latch for adjustment.
- Inspect all live parts for scarring, gouging, or sharp points that could contribute to excessive radio noise and corona. Check corona balls and rings for damage that could impair effectiveness.
- Inspect interphase linkages, operating rods, levers, bearings, etc. to assure that adjustments are correct, all joints are tight, and pipes are not bent.
- Check for simultaneous closing of all blades and for proper seating in the closed position.
- Inspect and check all safety interlocks while testing for proper operation.

Periodic Inspection and Maintenance (10 year)



The disconnect switch must be de-energized, disconnecting from all electrical power sources before servicing.

- Follow instructions for 5-year Routine Inspection and Maintenance



The Quality Name in High Voltage Switching

30 Georgia Avenue
Hampton, Georgia 30228
Phone: 770-946-4562
Fax: 770-946-8106
E-mail: support@southernstatesllc.com
<http://www.southernstatesllc.com>

©2022 Southern States, LLC
IB-101-EV2H 245-R7 07282022 Printed U.S.A.