



## **TYPE CBL-T**

Copper Center Break “V”  
Disconnect Switch

15.5 – 72.5 kV, 1200A

**INSTALLATION &**

**INSTRUCTION**

**MANUAL**



## **ATTENTION:**

Southern States will begin supplying a portion of new operating mechanism designs with Rapid-Set clevises for orders designed after 9/1/23. If your Operating Mechanism print calls for Rapid-Set clevises (see image below for an example), please utilize the instructions on the following pages for all linkage adjustments. If not, please adhere to the standard instructions provided.

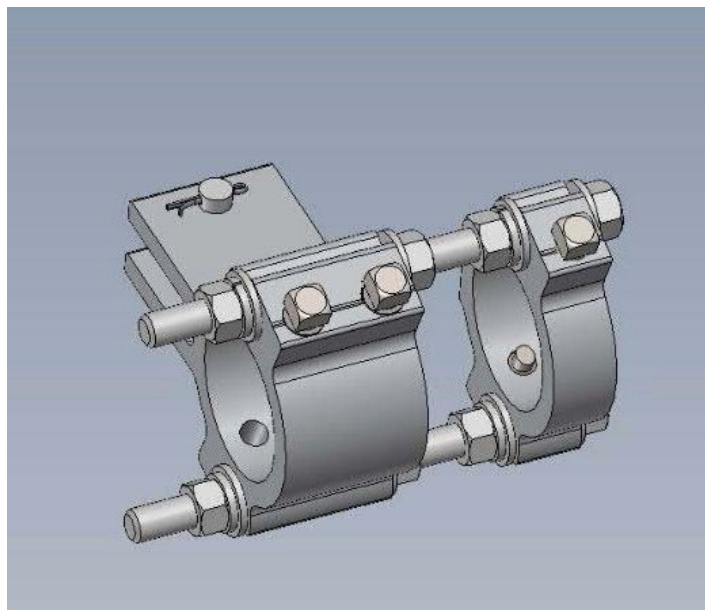



Please scan or use the link below for video instructions of Rapid-Set.  
[Southern States Rapid Set Instructions](#)

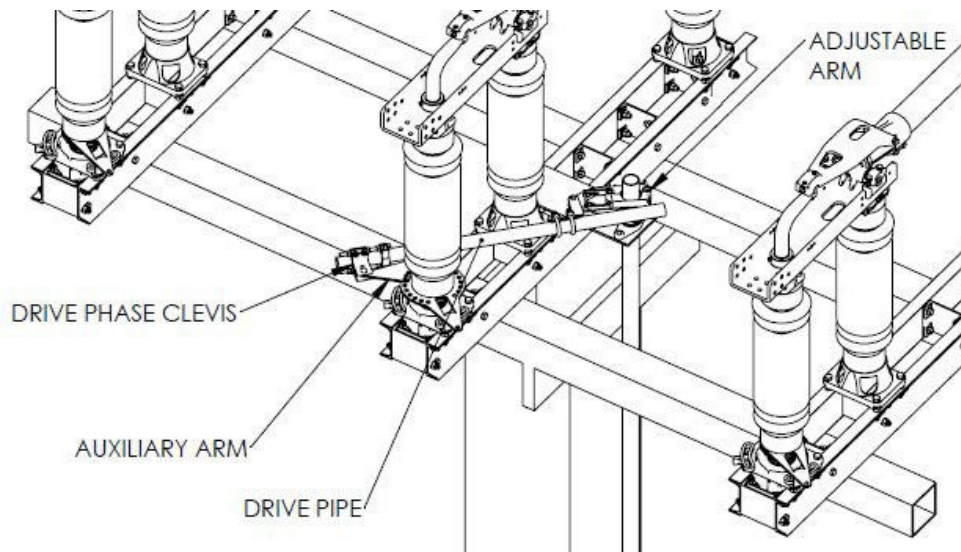

## STEP 1:

For operating mechanisms with drive pipe connected directly to the interphase pipe, skip ahead to Step 10.

## STEP 2:

Install the auxiliary arm by aligning the straight edge of the arm with the center of the vertical pipe and bolting it into place using two of the provided mounting holes. Do this with the switch phase set to the full closed position as shown below.

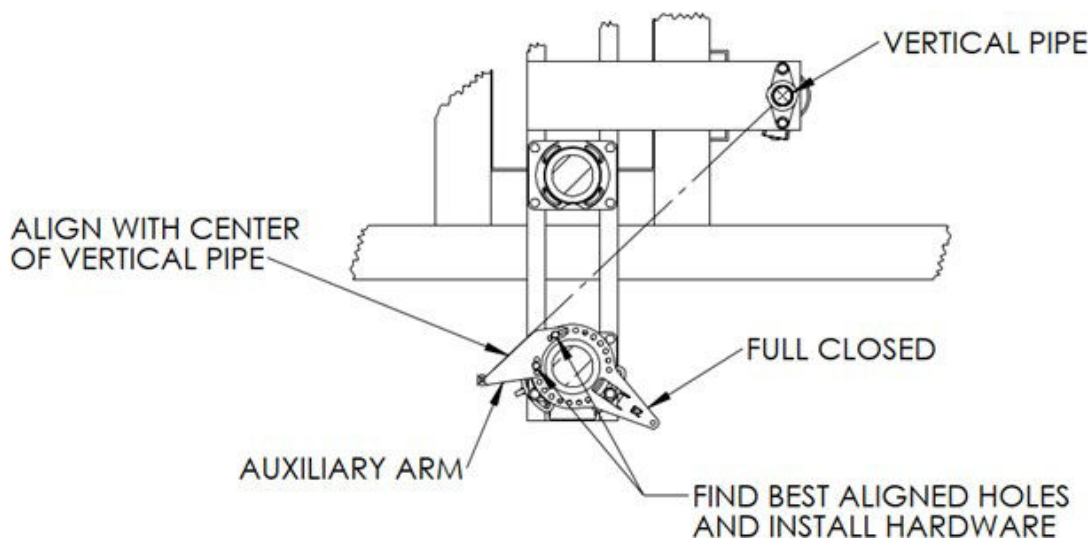

### STEP 3:

Install the adjustable arm with the radius "R" set to the recommended length provided in the operating mechanism drawings.

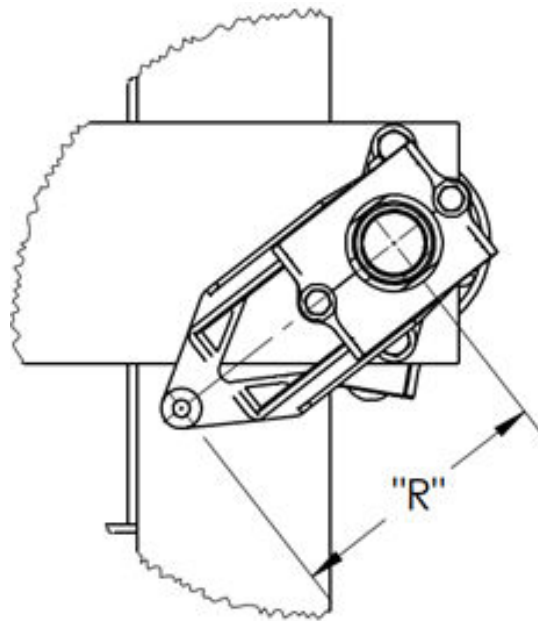

### STEP 4:

Install the auxiliary arm Rapid-Set clevis and drive pipe. Ensure that roughly 12" of pipe extends beyond the adjustable arm clevis connection so that the pipe makes contact with the adjustable arm in the position shown. This may be the open or closed position depending on the job specific drawings. The pipe should contact the adjustable arm in this position.

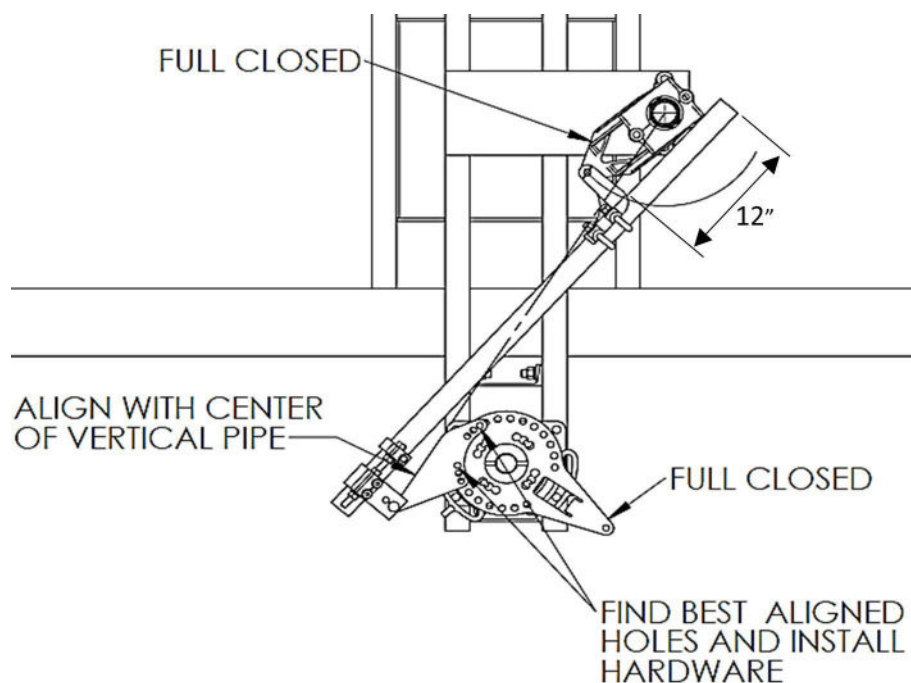

## STEP 5:

With the auxiliary arm properly aligned with the vertical pipe and the switch phase in the full closed position, pierce the pipe at both ends. **NOTE:** U-bolt style clevises require pre-drilling on all pipes thicker than SCH40. Drill guides are provided on the operating mechanism BOM when required. Pierce the adjustable arm clevis by hand tightening until it penetrates the pipe and continue until snug (note piercing screw may still have threads showing). Do not remove plastic caps from the Rapid-Set clevis at this time. To pierce the Rapid-Set clevis, tighten each piercing screw until the head contacts the aluminum extrusion. Do not over tighten.

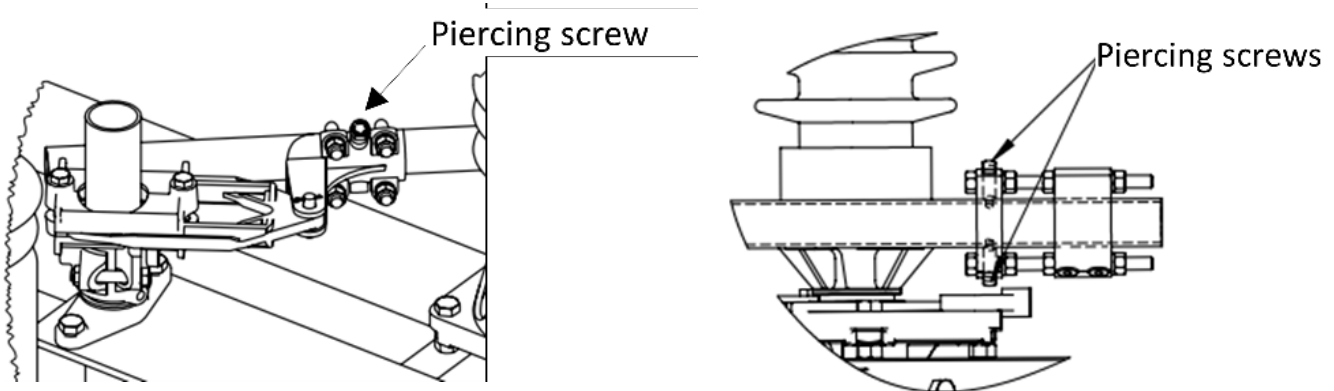

## STEP 6:

Begin to manually open the phase using the operator. Observe the phase closed and open stops during operation and modify the length of the adjustable arm as needed to provide the proper amount of travel. Lengthen the arm to add travel and shorten the arm to decrease travel. The mechanism should have sufficient toggle (spring load) during closed and open position. To balance the force at closed and open positions, adjust the length "L" of the Rapid-Set clevis by adjusting the four nuts shown below. Ensure that both the top and bottom sets are adjusted in equal increments.

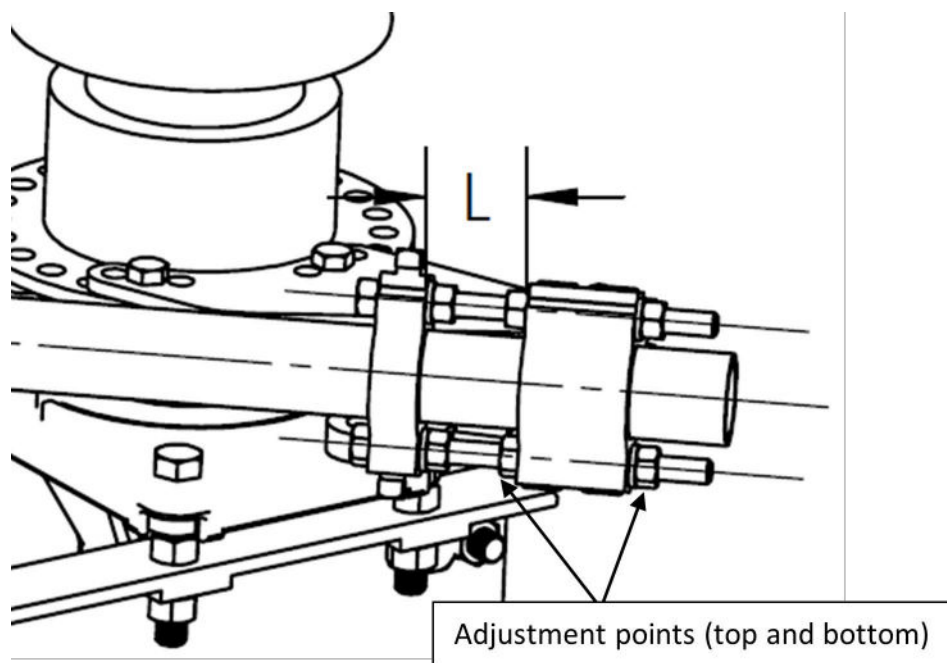

## STEP 7:

After the drive phase is adjusted to operate correctly, set all phases to full closed, and install the interphase pipe following the procedure below.

### For switches driven by the center phase:

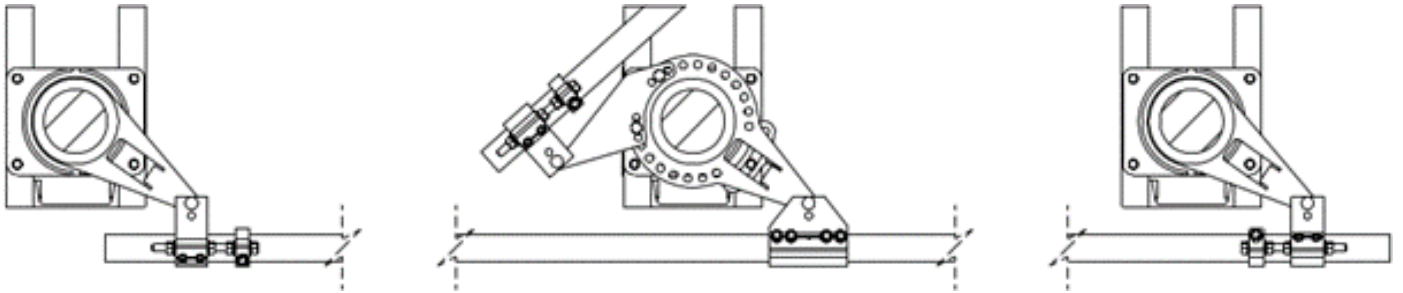

- a. With the interphase pipe centered and all clevises in place, pierce the interphase pipe at the locations shown. Do not remove plastic caps at this time.

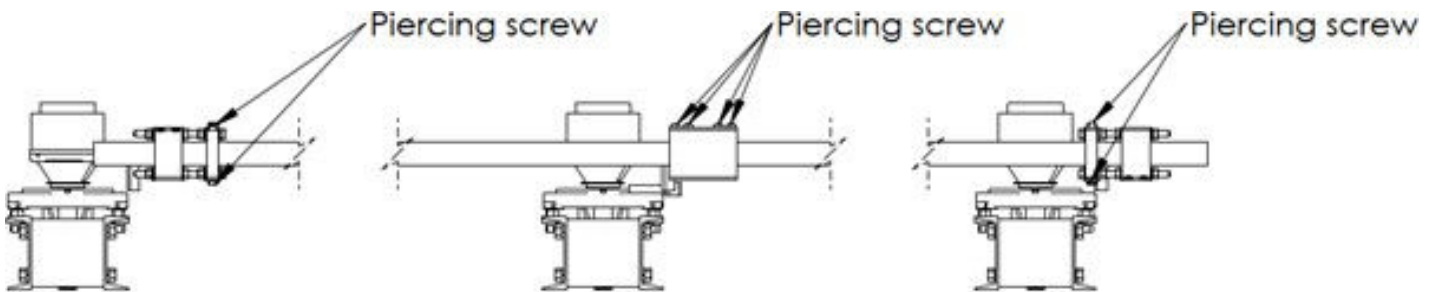

- b. Adjust the timing of the two driven phases by adjusting the length "L" of each Rapid-Set clevis.

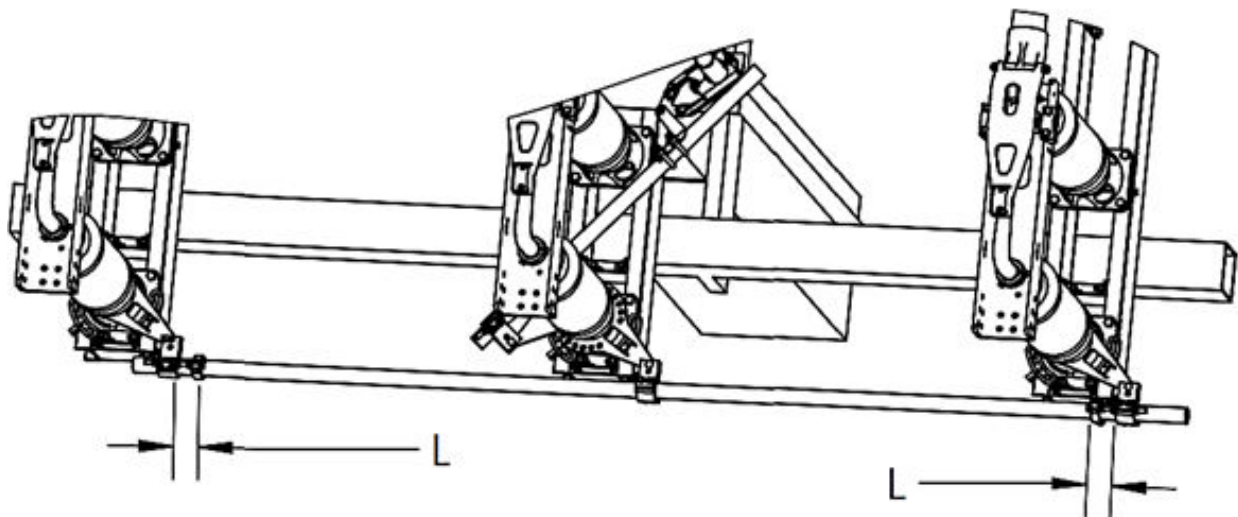

**For switches driven by one of the end phases:**

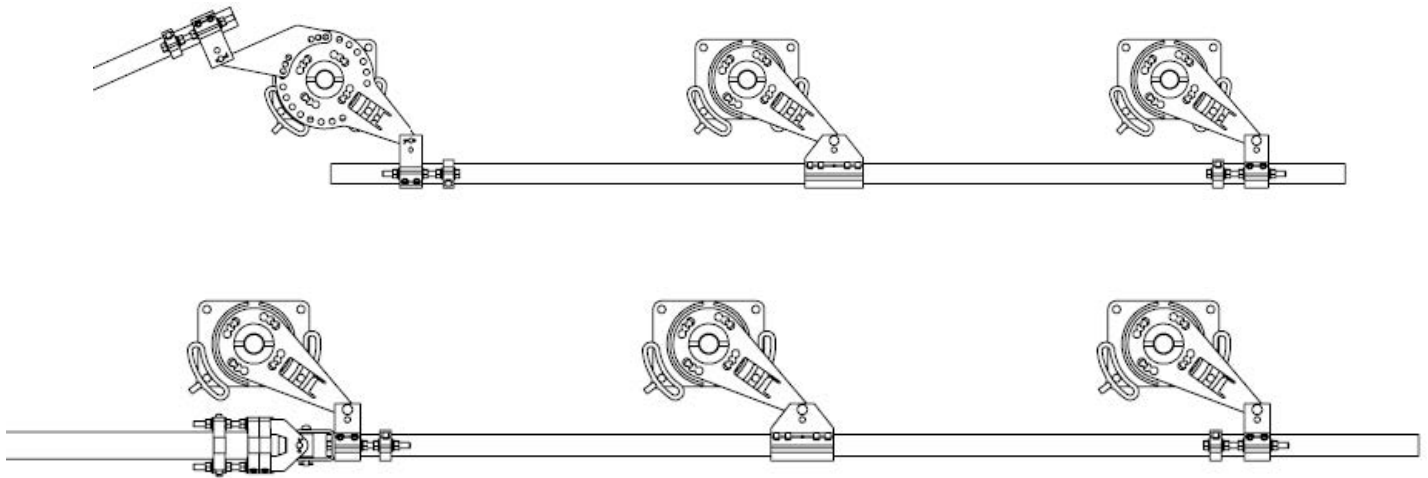

- a. With the interphase pipe centered and all clevises in place, pierce the interphase pipe with at the locations shown. Do not remove plastic caps at this time.

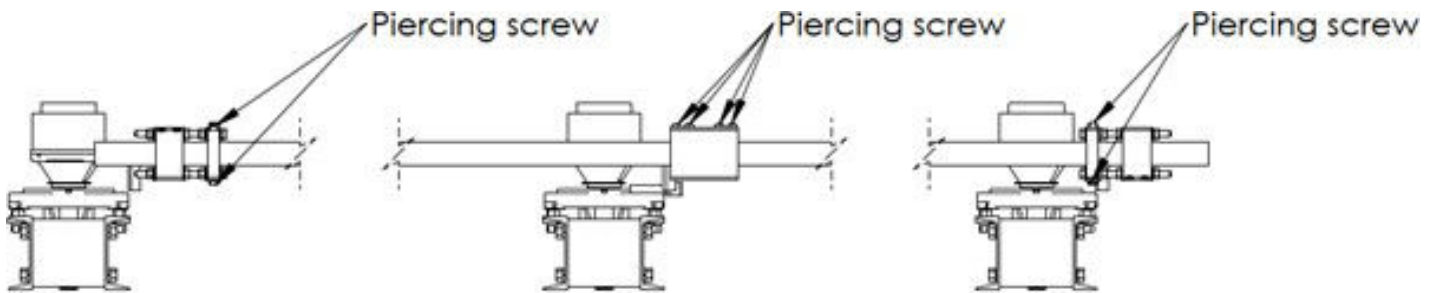

- b. Adjust the timing of the center phase by adjusting the length "L" of the Rapid-Set clevis attached to the drive phase.

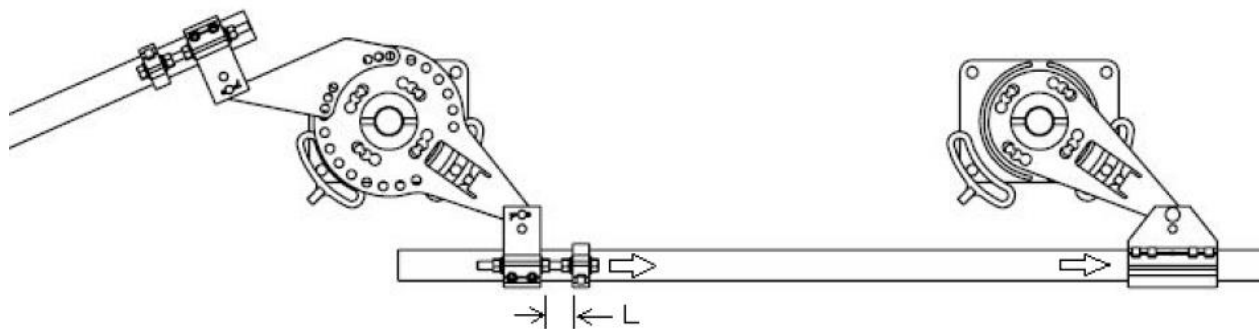



- c. Set the timing of the last phase by adjusting the length “L” of the Rapid-Set clevis attached to the last phase.

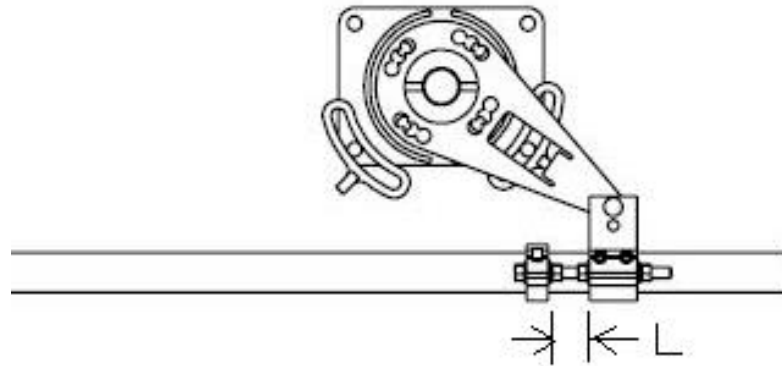

**STEP 8:**

With all the phases adjusted, open and close the three phase assembly and inspect for proper operation. Once adjustments are finalized, pierce all remaining connections (switch operator, adjustable arm, etc).

**STEP 9:**

Each Rapid-Set clevis is provided with 2 extra piercing screws. These are for optional use. To install these, remove the plastic cover caps and install them as shown below. Note, adding these will restrict any additional adjustment. Remove them before making any adjustments and then reinstall them on the bottom side of the clevis.

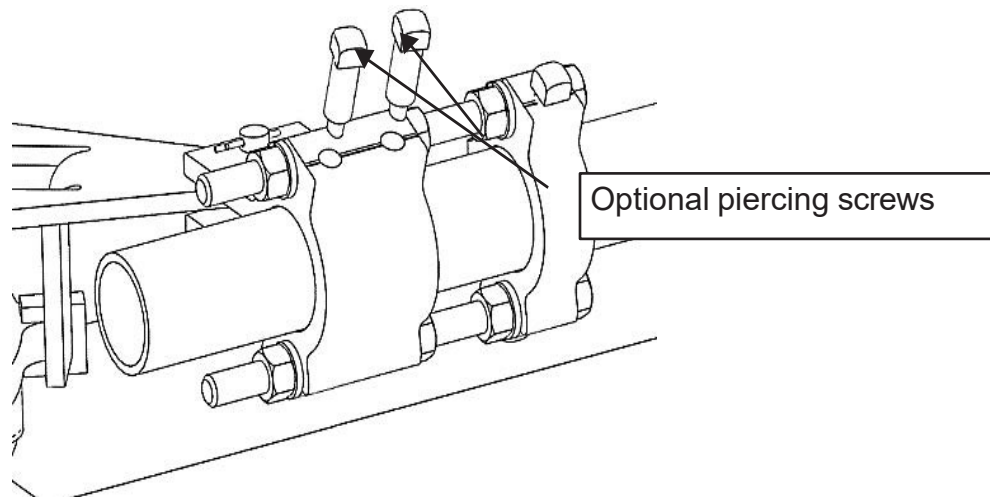

## STEP 10:

For Operating mechanisms with the drive pipe connected directly to the interphase pipe, start by installing the adjustable arm with the radius "R" set to the recommended length provided in the operating mechanism drawings.

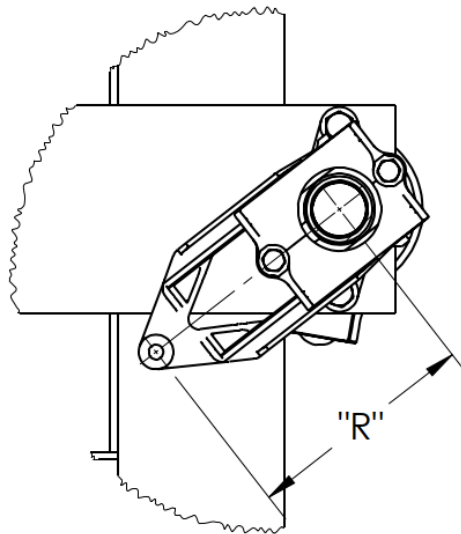

## STEP 11:

With all three switch phases set to the full closed position, assemble the interphase pipe as shown below. Be sure to center the pipe between all three connection points before piercing the connections shown in Step 12.

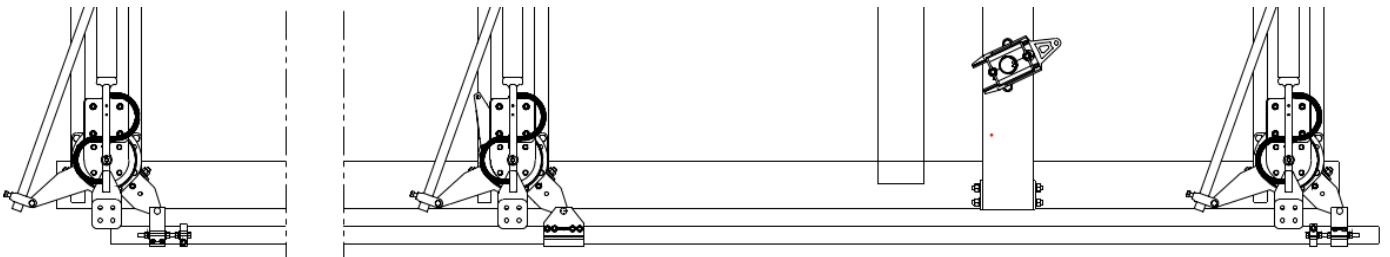

## STEP 12:

With all three phases set to the full closed position and the interphase pipe centered, pierce the interphase pipe at the locations shown. Do not remove plastic caps at this time.

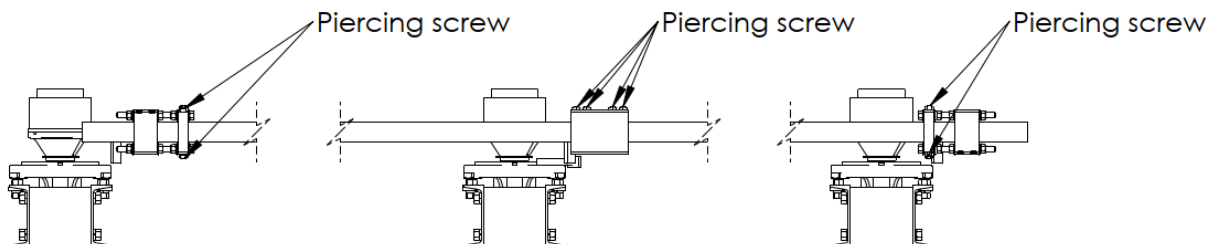

### STEP 13:

Install the drive pipe clevis to the interphase pipe at distance "L" shown on the operating mechanism drawing. Insert the drive pipe through both the drive pipe Rapid-Set and adjustable arm clevis.

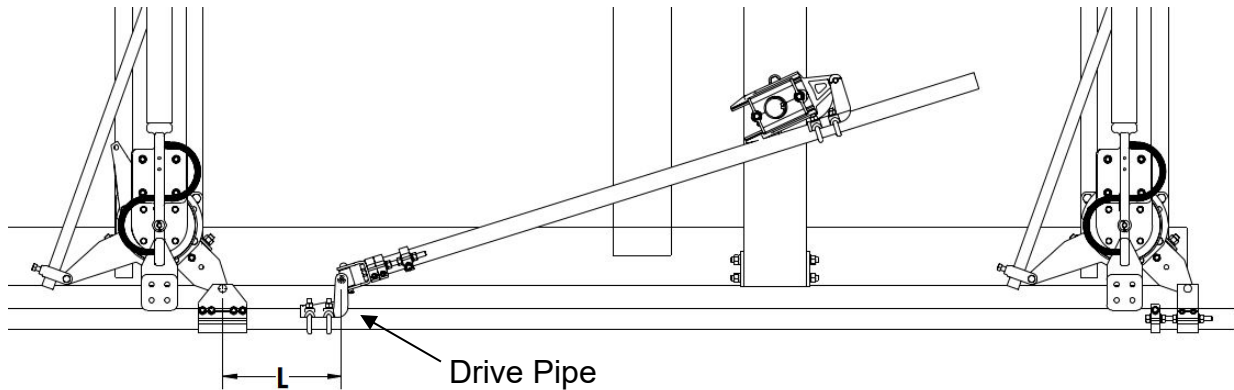

### STEP 14:

With the adjustable arm and switch phases set to the full closed position, pierce the drive pipe at both ends.

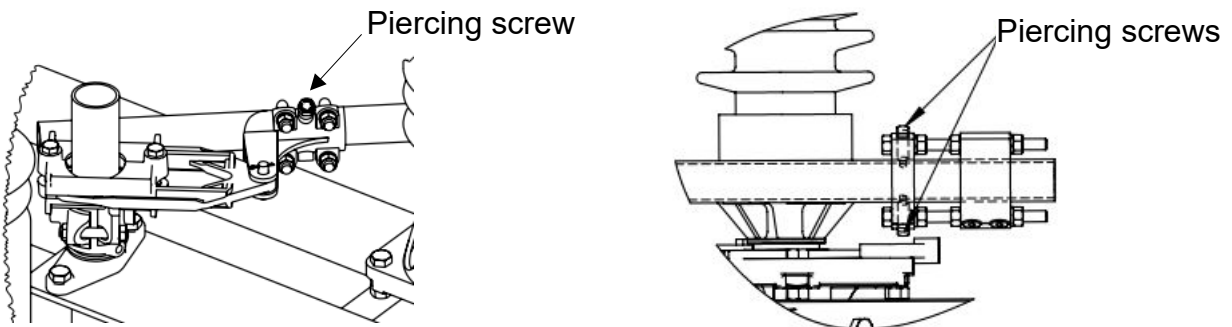

### STEP 15:

Adjust all stops on the outer two phases to ensure they are fully backed off. Begin to manually operate the three phase switch and focus on adjusting the center phase first. Adjust the length of the adjustable arm to get the correct amount of travel in the open and closed directions. The drive pipe Rapid-set should be used to balance the force in open and closed for the center phase.

## STEP 16:

Set the timing of the outside phases by adjusting the length "L" of the Rapid-Set clevis attached to the last phase.

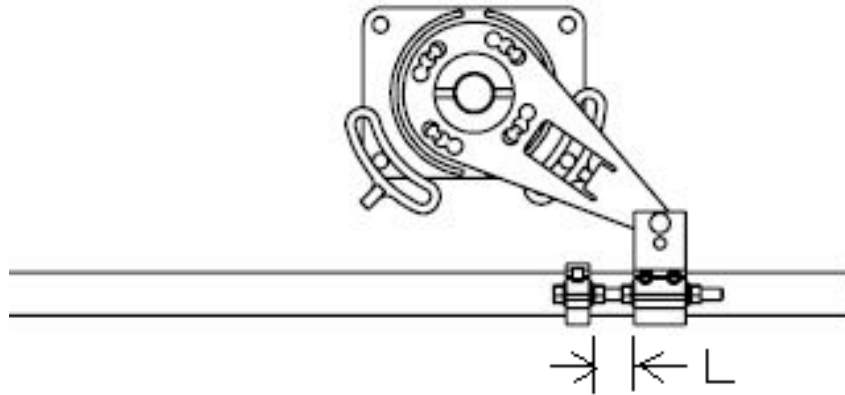

## STEP 17:

With all the phases adjusted, open and close the three phase assembly and inspect for proper operation. Once adjustments are finalized, pierce all remaining connections (switch operator, adjustable arm, etc).

## STEP 18:

Each Rapid-Set clevis is provided with 2 extra piercing screws. These are for optional use. To install these, remove the plastic cover caps and install them as shown below. Note, adding these will restrict any additional adjustment. Remove them before making any adjustments and then reinstall them on the bottom side of the clevis.

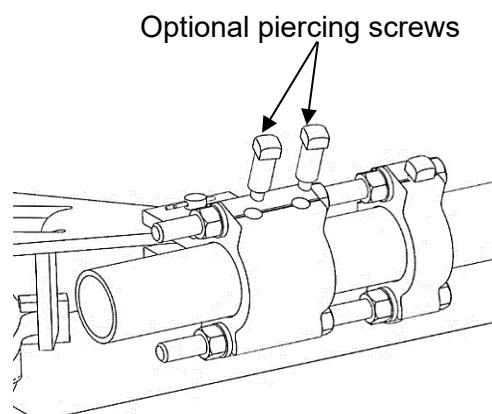

## Safety Information

### DANGER

IMPROPER HANDLING, INSTALLATION, OPERATION OR MAINTENANCE OF THIS EQUIPMENT MAY CAUSE IMMEDIATE HAZARDS WHICH WILL LIKELY RESULT IN SERIOUS PERSONNEL INJURY OR DEATH.

### WARNING

The equipment covered by this publication must be handled, installed, operated and maintained by qualified persons who have direct knowledge and experience dealing with the hazards involved and are thoroughly trained in the handling, installation, operation and maintenance of high voltage transmission and distribution equipment. These instructions are meant for only such **Qualified Persons**. They are not intended to be a substitute for adequate training and experience in safety procedures for this type of equipment.

A **Qualified Person** is one who is trained in and has skills necessary:

- to read and comprehend this instruction book – understanding that these instructions are general in nature
- to accept personal responsibility to prepare and maintain an intrinsically safe work environment and maintain control of the work site to safeguard all persons present
- to develop and implement a proper rigging, lifting, and installation plan along with all safety precautions required to insure safe and proper lifting and installation of the equipment.
- to distinguish between energized and non energized parts
- to determine proper approach distances to energized parts
- to properly work with and around energized or de-energized equipment that may be pressurized with gas
- for proper use of personal protective equipment, insulating and shielding materials, insulated tools for working near energized and /or pressurized electrical equipment
- to recognize and take necessary precautions for the unique and dynamic conditions of site and specialized equipment to maintain a safe work environment during handling, installation, operation, and maintenance of high voltage switching equipment

The instructions in this manual are general guidelines for this type of equipment and not specific to the equipment supplied. Portions of it may not be applicable or may not have complete instructions for your specific equipment.

If you do not understand any part of these instructions or need assistance, contact Southern States Service Division at 770-946-4562 during normal business hours (EST) or 770-946-4565 after normal business hours.

## LIMITED WARRANTY

Southern States, LLC (“SLLC”) warrants only to the Warranty Holder (hereinafter defined as the “End User” or the “Immediate Purchaser”, as applicable, pursuant to the terms and conditions of this Limited Warranty as set forth below), that the Product identified below will, upon shipment, be free of defects in workmanship and material for the applicable Warranty Period. The “Warranty Period” is that period of time during which this Limited Warranty is effective, and such period begins on the invoice date issued by SLLC for the Product, and continues until the earlier to occur of (1) the expiration of the Warranty Duration period, or (2) the Number of Operations, both as specified in the table below. If the Product is both purchased and installed within the United States or Canada, this Limited Warranty is granted to each end user of the Product who acquired the Product for its own use during the Warranty Period (“End User”). In all other situations, this Limited Warranty is granted only to the first purchaser of the Product (“Immediate Purchaser”) from SLLC. No primary or remote purchaser or owner of the Product who is not a Warranty Holder may claim any benefit under this Limited Warranty, or any remedial promise included in this Limited Warranty. SLLC shall, upon prompt written notice from the Warranty Holder, correct a nonconforming Product by repair or replacement at the sole discretion of SLLC of the nonconforming Product or any part or component of a nonconforming Product necessary in SLLC’s discretion to make such Product conforming. Any transportation charges, labor for removing, reinstalling the Product or part, and/or costs related to providing access to the Product shall be the responsibility of the Warranty Holder. Correction in this manner will constitute the Warranty Holder’s exclusive remedy and fulfillment of all SLLC’s liabilities and responsibilities hereunder. SLLC’s duty to perform under this limited warranty may be delayed, at SLLC’s sole option, until SLLC has been paid in full for all products purchased by the Warranty Holder. No such delay will extend the Warranty Period. If SLLC does not make such repair or replacement, SLLC’s liability for damages on account of any claimed nonconformity will in no event exceed the purchase price of the Product in question. This Limited Warranty does not apply to any Product that has been disassembled, repaired, or altered by anyone other than SLLC. This Limited Warranty will not apply to any Product that has been subjected to improper or abnormal use of the Product. SLLC has no responsibility to repair or replace any Product or component thereof manufactured by another party, but SLLC will assign, to the extent assignable, to the Warranty Holder any manufacturers’ warranty that applies to products and components not manufactured by SLLC.

THIS LIMITED WARRANTY IS EXCLUSIVE AND IN LIEU OF ALL OTHER WARRANTIES. THERE ARE NO OTHER EXPRESS, IMPLIED, OR STATUTORY WARRANTIES. ALL IMPLIED WARRANTIES WHICH MAY ARISE BY IMPLICATION OF LAW, OR APPLICATION OF COURSE OF DEALING OR USAGE OF TRADE, INCLUDING, BUT NOT LIMITED TO, IMPLIED WARRANTIES OF MERCHANTABILITY OR FITNESS FOR A PARTICULAR PURPOSE, NONINFRINGEMENT OR OTHERWISE ARE EXPRESSLY EXCLUDED. SLLC SHALL NOT BE LIABLE OR RESPONSIBLE FOR ANY CONSEQUENTIAL, INCIDENTAL, INDIRECT, EXEMPLARY, SPECIAL, OR PUNITIVE DAMAGES, EVEN IF SLLC HAS BEEN ADVISED OF THE POSSIBILITY OF SAME. THE WARRANTY HOLDER IS SOLELY RESPONSIBLE FOR THE SUITABILITY OF THE PRODUCT FOR ANY PARTICULAR APPLICATION.

<b>Product Purchased Region</b>	<b>Product Installed Region</b>	<b>Warranty Holder</b>	<b>Warranty Duration</b>
<b>U.S and Canada</b>	<b>U.S and Canada</b>	<b>End User</b>	<b>Five (5) Years</b>
<b>All Other Conditions</b>		<b>Immediate Purchaser</b>	<b>Earlier of 1 year from installation or 18 months from shipment</b>

**Southern States, LLC****Equipment Receipt, Installation, Use, Operation and Maintenance Terms****(“Terms of Use”)**

The purchaser (“Purchaser”) of certain Equipment (the “Equipment”) identified in the Instruction Manual accompanying these Terms of Use sold by Southern States, LLC (“Southern States”), by Purchaser’s acceptance or Use of Equipment in any way, agrees to the Terms of Use set forth below (the word “Use” herein means receipt, testing, inspection, installation, operation, maintenance and otherwise handling the Equipment):

- Purchaser represents and warrants that it is fully qualified to Use the Equipment, and that it is a sophisticated user of the Equipment with a high level of expertise in the Use of the Equipment and Purchaser knows that Southern States is relying on Purchaser’s sophistication and expertise with respect to the Equipment.
- The Purchaser will, within seven (7) days after receipt of the Equipment, inspect the Equipment and identify and notify Southern States in writing of any missing parts, damage or defects observed in the Equipment.
- The Purchaser will Use the Equipment, only in conformity with all manuals, data sheets and instructions provided by Southern States, and in keeping with sound engineering, utility and safety practice. Purchaser will at its own expense, provide all necessary labor, supplies, and facilities required to Use the Equipment.
  - The Purchaser may use its own personnel or engage a third party to Use the Equipment. The Purchaser shall insure that it only utilizes personnel who are fully qualified or certified by a reputable certification agency to Use the Equipment. In the event that Purchaser cannot find such qualified personnel, the Purchaser will notify Southern States and seek its advice to determine a mutually agreeable solution.
  - By separate agreement, Southern States may provide such services and the personnel to conduct such services in connection with the installation of the Equipment. In the event Southern States agrees to provide personnel to install, maintain, and operate the Equipment, such personnel will function only in an advisory capacity and shall have no responsibility for the supervision, or the quality or workmanship of such installation, maintenance, or operation of the Equipment.
- The Purchaser shall not install and operate the Equipment in a way such that a single point of Equipment failure leads to a cascading event or consequential damage to any person or property. Purchaser shall ensure redundancy in its system at all times. Purchaser acknowledges and agrees that electric service is by nature subject to interruptions due to Equipment failures and shall not agree to provide service free from the effects of Equipment failures.
- The Equipment will be maintained and inspected as provided by this instruction manual and in compliance with best industry practices, but in no event will the Equipment be inspected and tested less frequently than once in every 6 months.
- The Purchaser shall not repair, dismantle, or alter any of the Equipment without Southern States’ written consent.
- Any failure of Equipment either in service, testing or inspection will be promptly reported in writing to Southern States within 24 hours of the failure so that adequate evidence can be collected, appropriate diagnostic tests can be conducted, and analysis of the failure can be determined.
- Southern States will have no liability for any direct, indirect, consequential or remote damage or injury, whether or not foreseen or foreseeable, to the Purchaser or any third party or person for any damages or injury to person or property caused by Purchaser’s or any third party’s actions, whether or not negligent, in the Use of the Equipment. Purchaser shall indemnify and hold Southern States and its employees, officers and directors against any damage or injury caused in whole or part by Purchaser’s or any third party’s action whether or not negligent, resulting from the Use of the Equipment. Southern States expressly rejects any liability to third parties. The Purchaser expressly waives any claim against Southern States, its employees, officers, directors and affiliates, for injury or damage to person or property resulting from Use of the Equipment not directly and solely caused by Southern States’ negligence. For the purposes of clarity, Southern States shall not be liable, and be fully indemnified by the Purchaser, for the following related to the Equipment: normal wear and tear, excessive use and loading, improper interference or maintenance on the part of the Purchaser or third parties, incomplete or false information given by the Purchaser, inappropriate or improper Use, faulty operation, installation or start-up, faulty or careless handling, improper maintenance, use of unsuitable operating materials/substitute materials, defective construction work, hazardous ambient conditions unknown to the Purchaser, chemical, electro-chemical or electrical influences, changes to the subject of delivery made without Southern States consent.
- In the event that Southern States is found by a court of competent jurisdiction or a properly empaneled arbitral body to be liable to the Purchaser for any reason, Southern States shall be entitled to a reduction in the liability by taking into account the exceptions provided by statute, law, and any counterclaims Southern States may have against Purchaser.
- The failure of Purchaser to comply with these Terms of Use herein shall void any and all warranties related to the Equipment. These Terms of Use shall be deemed to be part of the binding contractual agreements between Purchaser and Southern States related to the Equipment and shall govern over any inconsistent term or provision in such other contractual agreements.





## Type CBL-T

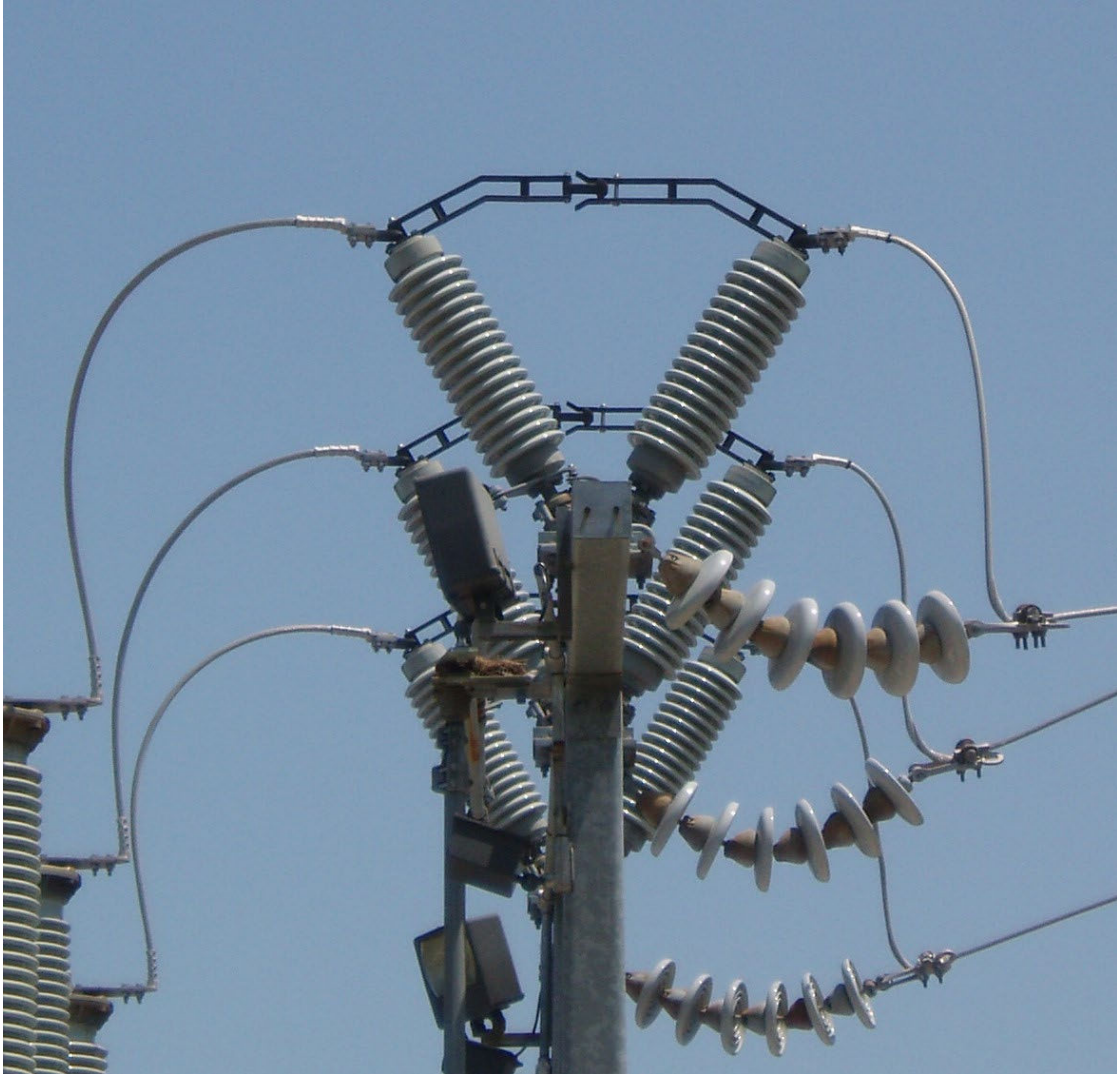

# Table of Contents

<b>Chapter</b>	<b>Page</b>
Table of Contents .....	VIII
List of Tables and Figures .....	IX
Summary & Introduction .....	6
Summary .....	6
Important .....	6
Introduction .....	7
Ratings .....	8
Product Description .....	9
Typical Disconnect Switch .....	9
Receiving, Handling & Storage .....	10
Unpacking .....	10
Storage .....	10
Installation & Adjustment Procedures .....	11
Recommended Tools & Values .....	11
Preferred Switch Assembly Method: .....	12
Mounting Switch on Structure .....	15
Single Pole Adjustments .....	15
Arcing Horn Adjustment .....	15
Operating Mechanism .....	16
Operating Mechanism Adjustment (Three Phase Installation) .....	19
Final Switch Adjustments (Tuning) .....	22
General Instructions for Threaded Clevises .....	24
Recommended Inspection Maintenance .....	25
Patrolling Inspection (6 Months) .....	26
Routine Inspection and Maintenance (5 year) .....	26
Periodic Inspection and Maintenance (10 year) .....	26

---

The Quality Name in High Voltage Switching

## List of Tables and Figures

<b>Tables</b>	<b>Page</b>
Table 1: Ratings Table .....	8
Table 2: Recommended Tools and Torque Values .....	11
Table 3: Recommended Installation and Maintenance Table.....	25

<b>Figures</b>	<b>Page</b>
Figure 1: Typical CBL-T Single Pole Switch & Common Terminology .....	9
Figure 2: Live Parts Mounting .....	12
Figure 3: Rotating Insulator Bearing Housing .....	13
Figure 4: Blades Shown Fully Open .....	14
Figure 5: Contacts Shown Fully Closed .....	14
Figure 6: Optional Arcing Horn in Closed Position .....	16
Figure 7: Typical Operating Pipe Arrangement .....	17
Figure 8: Typical Operating Arrangement .....	17
Figure 9: Counterweight Assembled .....	18
Figure 10: Top View of Adjustable Arm Assembly .....	19
Figure 11: Match-Marked Hinge Clamp and Pipe .....	20
Figure 12: Piercing Pipe Wall .....	21
Figure 13: Type HOGO (High Output Geared Operator) Front View .....	22
Figure 14: Type SEGO (Safety Enhanced Gear Operator) .....	23

## Summary & Introduction

### Summary

These instructions do not intend to cover all details or variations in equipment, or provide for every possible contingency to be met in connection with installation, operation or maintenance. Should information be desired or should particular problems arise which are not covered sufficiently for the purchaser's purposes, the matter should be referred to the local Southern States Representative.

The contents of this instruction manual should not become part of or modify any prior or existing agreement, commitment or relationship. The sales contract contains the entire obligations of Southern States. The Warranty contained in the contract between the parties is the sole warranty of Southern States. Any statements contained herein do not create new warranties or modify the existing warranty.

### Important

The information contained herein is general in nature and not intended for specific application purposes. It does not relieve the user of responsibility to use sound practices in application, installation, operation, and maintenance of the equipment purchased. Southern States reserves the right to make changes in the specifications shown herein or to make improvements at any time without notice or obligations. Should a conflict arise between the general information contained in this publication and the contents of drawings or supplementary material, or both, the latter shall take precedence.

## Summary & Introduction

### Introduction

Southern States Type CBL-T switch is a center side break, low profile “V” configuration disconnect switch for pole or structure mounting. It has two rotating insulators placed 60° apart and can be mounted upright, inverted, or at any desired angle. The current carrying parts are copper and copper alloy with silver-to-copper transfer points. Standard mounting dimensions are 9¾” x 9¾”.

The CBL-T is designed for simplicity, ruggedness, reliability and attractive appearances. Using only two insulators per phase results in cost and weight savings. All switches, including 69kV, are normally shipped factory assembled with insulators, and fully adjusted.

The CBL-T switch may be operated with either a manual operator (swing handle or worm gear) or a Southern States Type VM-1 Motor Operator

The instructions contained within this manual are necessary for the safe installation, maintenance, and operation of the Type CBL-T switch. A qualified person, familiar with this of type equipment, should carefully read and follow the instructions.

These instructions are intended to provide a general guideline for the installation, adjustment, and maintenance of the Type CBL-T switch. All details, equipment variations, and potential conditions may not be covered in this manual. Contact Southern States, LLC in the event conditions associated with a specific application are not sufficiently addressed.

All photographs and sketches in this manual are for illustration purposes only and may not be to scale. Refer to the Unit Assembly drawing or the Operating Mechanism drawing provided with each disconnect switch for specific details. During installation, it may be necessary to make adjustments other than those described in this manual. Contact your local representative or the factory if questions should arise.

Southern States After Sales and Service Department is available for field installation assistance along with providing parts support for all Southern States products.

Contact After Sales and Service at 770-946-4562, 7:30am-4:00pm EST Monday-Friday.  
After Hours: 770-946-4565

Distinctive signal words are used to indicate the degree of hazard that may be encountered by the user. Identification of the signal words and their definition follow:

**▲ DANGER**

Indicates an imminently hazardous situation, which, if not avoided, will result in death or serious injury.

**▲ CAUTION**

Indicates a potentially hazardous situation, which, if not avoided, may result in minor or moderate injury. It may also be used to alert against unsafe practices.

**▲ WARNING**

Indicates a potentially hazardous situation, which, if not avoided, could result in death or serious injury.

## Ratings

Table 1: Ratings Table

RATINGS					
MAXIMUM VOLTAGE (kV)	15.5	27	38	48.3	72.5
BIL (kV)	110	150	200	250	350
Rated Power Frequency	60 Hz				
Continuous Current	1200 A				
Short-Time Symmetrical Withstand (3 Sec.)	38 kA RMS				
Peak Withstand	99 kA				
Ambient Temperature Rating	-40°C to +50°C Standard -50°C Optional				

## Product Description

### Typical Disconnect Switch

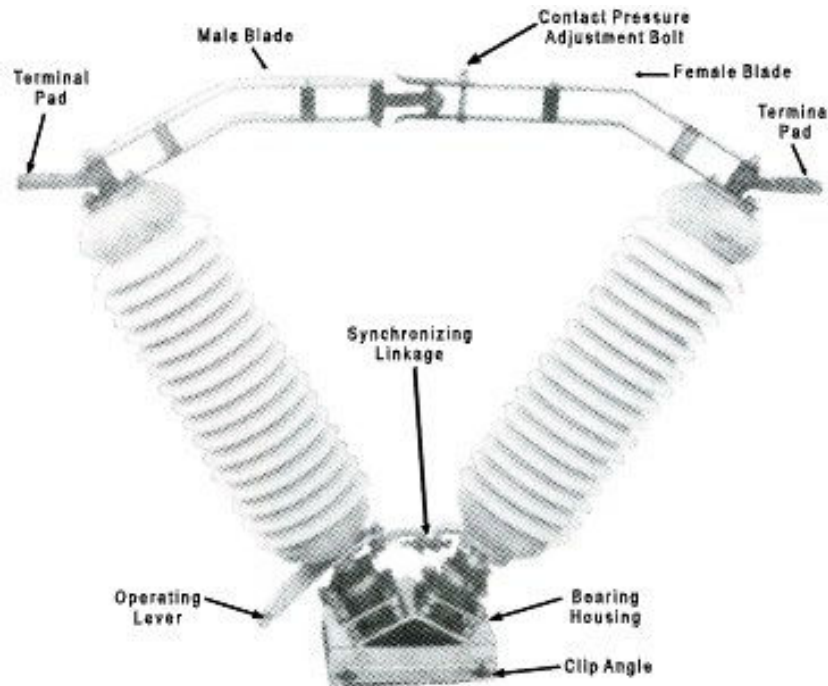

**Figure 1: Typical CBL-T Single Pole Switch & Common Terminology**

**Contacts** – The CBL-T switch has Silver-to-Copper contacts. A heavy silver insert, brazed on either side of the male contact, provides low resistance, high conductivity current transfer points. On the hinge end, silver rings are brazed to the terminal (hinge) assembly which make contact continuously with the copper truss blade.

**Six Hole Terminal Pads** – Provided as standard, the 6-hole terminal pads are suitable for either 2 or 4-hole connection on NEMA standard drilling patterns.

**Compact Base** – The base is simple and can be mounted almost anywhere. The base is galvanized steel and includes leveling screws for the insulators, adjustable open and close stops and mounting hole for attachment to the structure.

**Bearings** – The bearings on the CBL-T switch are stainless steel balls and races. They are rugged, maintenance free, life time bearings. All ratings are supplied with insulator leveling bolts.

**Adjustable Open and Close Position Stops** – These stops are provided on the rotating insulator stacks to provide individual adjustments, allowing maximum synchronization of the three phase assembly.

## Receiving, Handling & Storage

### Unpacking

The CBL-T switch consists of: Live parts – blades with hinges, terminal pads and contacts; base housing with mounting angles attached; insulators; interphase and control pipes with hardware; and outboard bearing and operator.

Unpack the equipment and check for damages or material shortages immediately. The bill-of-material from the Unit Assembly (switch) and Operating Mechanism drawings should be used for this purpose. If damage or a shortage is noted, file a claim immediately with the carrier and contact the factory.

### Storage

All components of the Cole Type P center break disconnect switch are suitable for outdoor use. Keep bearings out of standing water. Keep upright and support live parts with base. If a motor operator is furnished, be sure to connect the heater circuit using the provided external wiring, while the unit is in storage. Discard the wiring upon installation.

*Typical crating is intended for storage less than 1 year.* If long term storage is required please notify factory at time of order placement so that special crating can be used.



## Installation & Adjustment Procedures

### Recommended Tools & Values

Table 2: Recommended Tools and Torque Values

Recommended Tools		Recommended Torque Values	
Type	Sizes	Bolt/Nut size	Torque (Ft-lb)
Hand Wrenches and/or Sockets	15/16", 3/4", 5/8", 9/16"	1/2"	50 (S. Steel) 40 (All Others)
Drill Bit	1/4"	5/8"	92
		3/4"	127
		1"	286

## Installation & Adjustment Procedures

### Preferred Switch Assembly Method:

1.3 When insulators are shipped installed on the switch and the switch has been adjusted at the factory, proceed to Mounting Switch on Structure

1. Set up bearing housing with clip angles installed at ground level. Make sure clip angles are level and secured so that the switch does not tip over when insulators are installed.
2. Bolt insulators to rotating flanges of bearing housing.
3. Install male blade to top of insulator with mounting bolts supplied (**Figure 2**). Note that male blade is on the same side as operating lever.

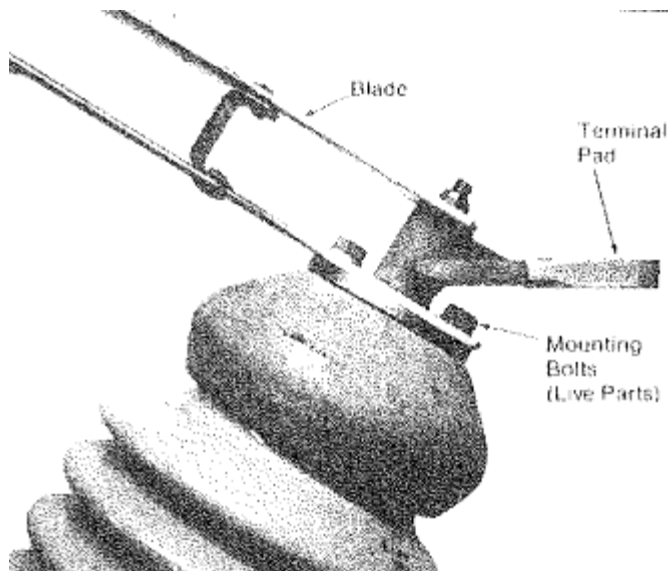

**Figure 2: Live Parts Mounting**

## Installation & Adjustment Procedures

4. With male blade in closed position, adjust and level male blade plug to be centered over bearing housing. Use jacking bolts (**Figure 3**) to make these adjustments.

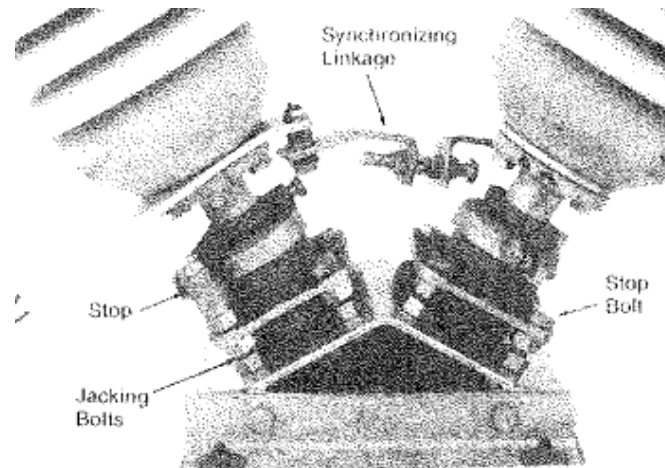

**Figure 3: Rotating Insulator Bearing Housing**

5. Install female blade, level and adjust to mate with male blade. The synchronizing linkage may require slight adjustment to ensure that both blades center together in the closed position. Set stop adjustment bolts on bearing housing for the closed position.
6. Adjustment of switch in the open position – Rotate the insulator stacks to the open position. The blades should travel 90 degrees. Set stops on bearing housing to provide 90 degree blade opening. Refer to **Figure 4**. Open position stop is on female blade side.



## Installation & Adjustment Procedures

**Figure 4: Blades Shown Fully Open**

7. Adjustment of contact pressure – Rotate the blade assemblies into the closed position. The pressure adjusting bolt should be left loose so as not to apply any pressure during this first closing position. Tighten the adjusting bolt until the contact surfaces touch. Then tighten 1/8 turn. Refer to **Error! Reference source not found.**

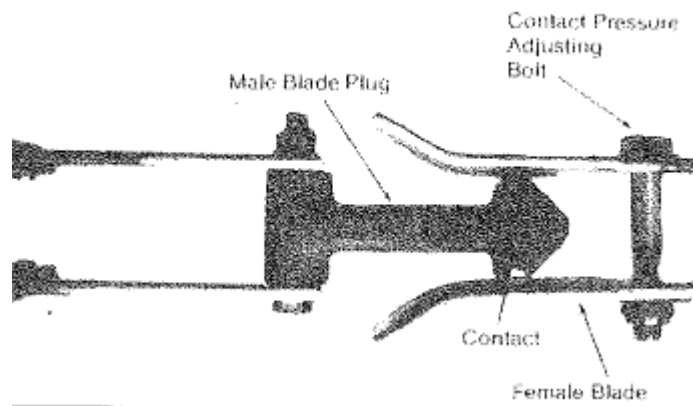

**Figure 5: Contacts Shown Fully Closed**

## Installation & Adjustment Procedures

### Mounting Switch on Structure

1. Tie blades in closed position to prevent switch from opening while lifting.
2. Rigging used to lift the poles should be attached to the clip angles or bearing housings. **Do not lift switch by attaching to the live parts.** Refer to the Operating Mechanism Drawing for proper placement of switch on the structure.
3. Check mounting surface for unevenness. Use shims under the clip angles to level, if necessary.
4. Bolt clip angles solidly to the structure.

### Single Pole Adjustments

Be sure each single pole is properly adjusted before connecting the controls and operators.

1. With the switch bolted solidly to the structure, check to make sure that the single pole opening is as specified in the single pole assembly drawing.
2. Check blades to be sure they contact squarely and smoothly. If they do not, refer to **Preferred Switch Assembly Method:** section.
3. After connecting the bus, all adjustments should be rechecked.

### Arcing Horn Adjustment

If optional arching horns are supplied and adjustment is required, proceed as follows:

1. With switch in closed position, adjust horns to make contact (**Figure 6**).
2. Open switch slowly. Horns should make sliding contact along their entire length when the switch is closing or opening.
3. Adjustment of the arcing horn can be done by grasping it firmly and bending until the action described above is achieved.

## Installation & Adjustment Procedures

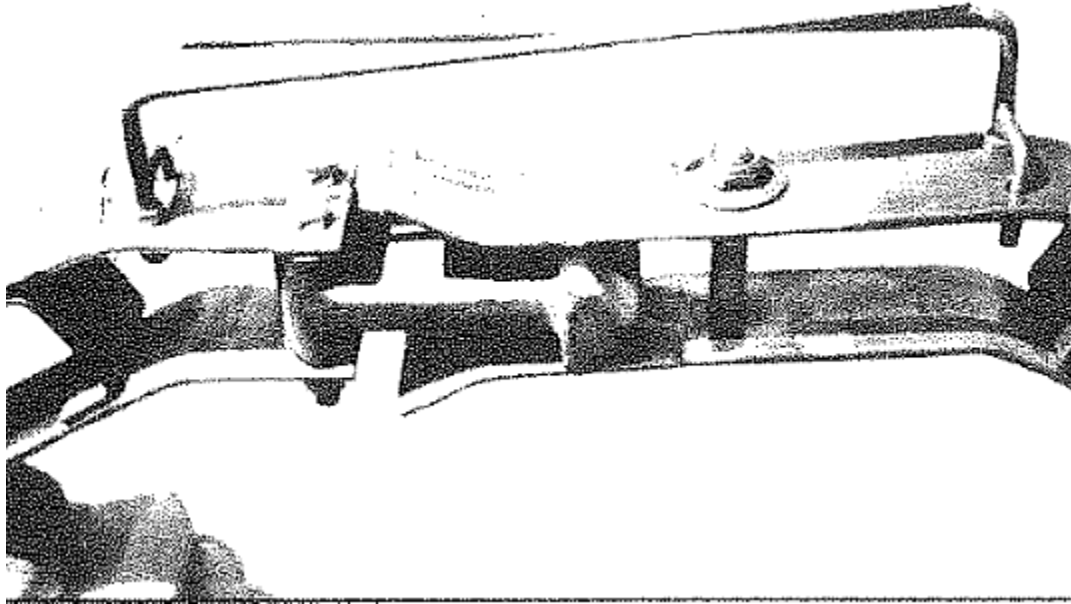

**Figure 6: Optional Arcing Horn in Closed Position**

### Operating Mechanism

1. Lay out all parts and check each one against the bill of materials on the Operating Mechanism Drawing (Op-Mech).
2. Use the Op-Mech Drawing to install mounting brackets, bearings, bushings, pipe clevises, manual operating device, Adjustable Arm, and other components - **Figure 7** and **Figure 8**.

**⚠ CAUTION**

The Pipe Collar must support the entire weight of the Vertical Operating Pipe. Do not allow the manual operating housing to bear any of the Vertical Pipe weight.

Installation & Adjustment Procedures

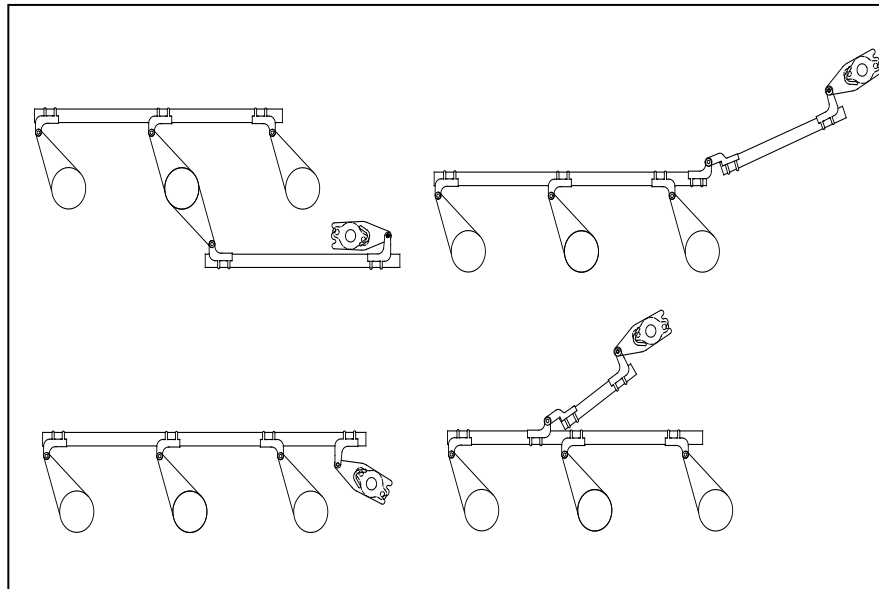

**Figure 7: Typical Operating Pipe Arrangement**

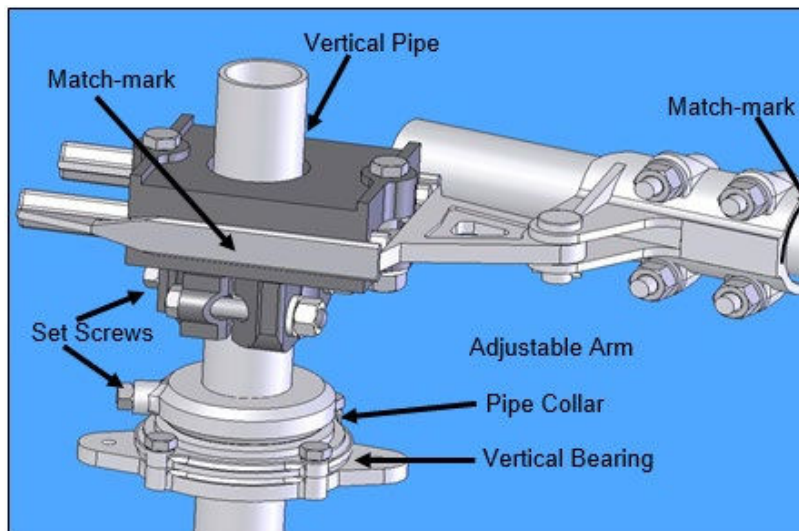
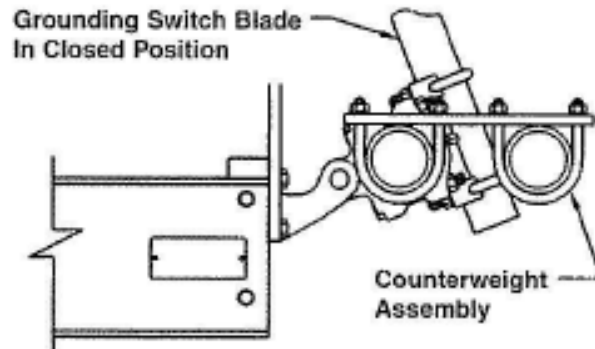

**Figure 8: Typical Operating Arrangement**

3. Tighten all setscrews to securely grip the pipe. **Do not drive any screws through the pipe wall at this time.**

## Installation & Adjustment Procedures

4. If furnished with a Counterweight, refer to the Grounding switch Unit Assembly and **Figure 9** for installation details.



**Figure 9: Counterweight Assembled**

5. After mounting all operating mechanism components, use any convenient means to match-mark all clevis connections, Adjustable Arm, and manual operator attachments to check for slippage during trial operations.



## Installation &amp; Adjustment Procedures

## Operating Mechanism Adjustment (Three Phase Installation)

1. Position all Grounding Switch poles closed and all Disconnect Switch poles open.
2. The Adjustable Arm setting on the Op-Mech Drawing is a calculated dimension. Adjust as required for exact setting.
3. The Adjustable Arm radius is **too short** if the Grounding Switch does not open fully (Blade in horizontal position). To correct:
  - Check for slippage
  - Return the switch to the closed position.
  - Operate the switch toward the open position to remove pressure on the linkage.
  - Loosen Adjustable Arm and Clevis Bolts - **Figure 10**.

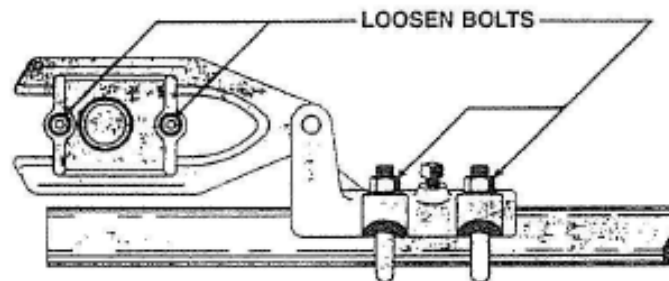
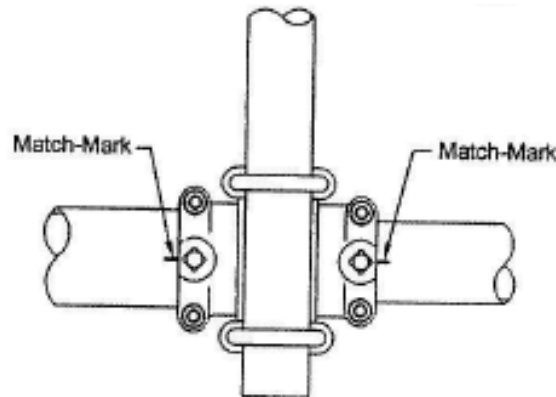

**Figure 10: Top View of Adjustable Arm Assembly**

- Lengthen the Adjustable Arm radius approximately  $\frac{1}{4}$ ". Shorten the pipe to allow the Clevis to reposition itself the same distance.
  - Re-tighten the Adjustable Arm and Clevis Clamping Bolts.
  - Test Operate. Re-adjust as necessary.
4. The Adjustable Arm radius is **too long** if the Grounding Switch reaches the fully open position (Blade in horizontal position) before the switch operator reaches the open position. To correct:
    - Check for slippage
    - Return the switch to the closed position.
    - Operate the switch toward the open position to remove pressure on the linkage.
    - Loosen Adjustable Arm and Clevis Bolts - **Figure 10**.
    - Shorten the Adjustable Arm radius approximately  $\frac{1}{4}$ ". Lengthen the pipe to allow the Clevis to reposition itself the same distance.

## Installation & Adjustment Procedures

- Re-tighten the Adjustable Arm and Clevis Clamping Bolts.
  - Test Operate. Re-adjust as necessary.
5. All poles of the fully adjusted switch should close completely and operate together. Slight adjustment of the Hinge Assembly Clamping Bolts may be necessary to coordinate all three poles. Rapid operation of the manual handle may be necessary to achieve full closing of all three poles.
  6. No adjustment of the Grounding Switch Blade closest to the Operating Arm is necessary.
  7. The Grounding Switch Blade on the remaining two poles will require “lead” (Blade movement in advance of the Blade on the pole closest to the Operating Arm):
    - With the Grounding Switch in the open position, match-mark the Hinge Clamp and pipe.
    - Adjust “lead” by elevating the Blade slightly - **Figure 11**.



**Figure 11: Match-Marked Hinge Clamp and Pipe**

- Be sure the Blade Tip rests against the Blade Stop when the Blade is in the closed position.
  - Test Operate. Re-adjust as necessary.
8. When the switch is fully adjusted:
    - Pre-drill pipe for setscrews with the Threaded Drill Guides supplied and a ¼” drill.
    - Securely tighten all bolts.
    - Tighten setscrews until pipe wall is pierced - **Figure 12**

**⚠ CAUTION**

Penetrate the aluminum pipe only with setscrews. Forcing setscrews into the steel pipe can result in casting breakage.

Installation & Adjustment Procedures

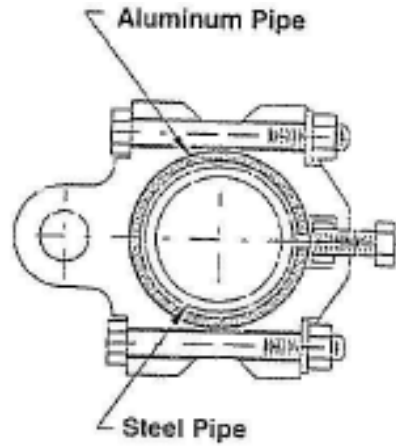

**Figure 12: Piercing Pipe Wall**

## Installation & Adjustment Procedures

### Final Switch Adjustments (Tuning)

1. The operating mechanism is intended to fully open and fully close the disconnect switch by rotating the vertical operating pipe about 180° using an operator (manual or electrical). The interphase pipe controls the individual operation of each switch pole, using a push/pull control. The reach rod translates the motion of the vertical operating pipe to the interphase linkage. The adjustable arm controls the total amount of switch operation available.

**HINT:** For easiest adjustment start with the reach rod connected to the drive phase and the interphase pipe disconnected from the other two phases. Once the drive phase is properly adjusted, connect the interphase pipe and continue tuning the other two phases, one at a time.

2. Switch Operating Devices:

#### 1.3 Worm gear operator (HOGO – High Output Geared Operator) (Optional)

2.1.1. The weight of the vertical operating pipe should be supported by pipe collar (Error! Reference source not found.) by maintaining the 1/4" - 3/8" gap (Figure 13).

2.1.2. When the switch is properly adjusted the operator handle should hang freely in both the open and closed positions to permit the use of a customer supplied padlock. Refer to Figure 13.

**CAUTION** Be aware that there is an adjustable stop on the operator. **Do not over operate as damage will occur to the operator.**

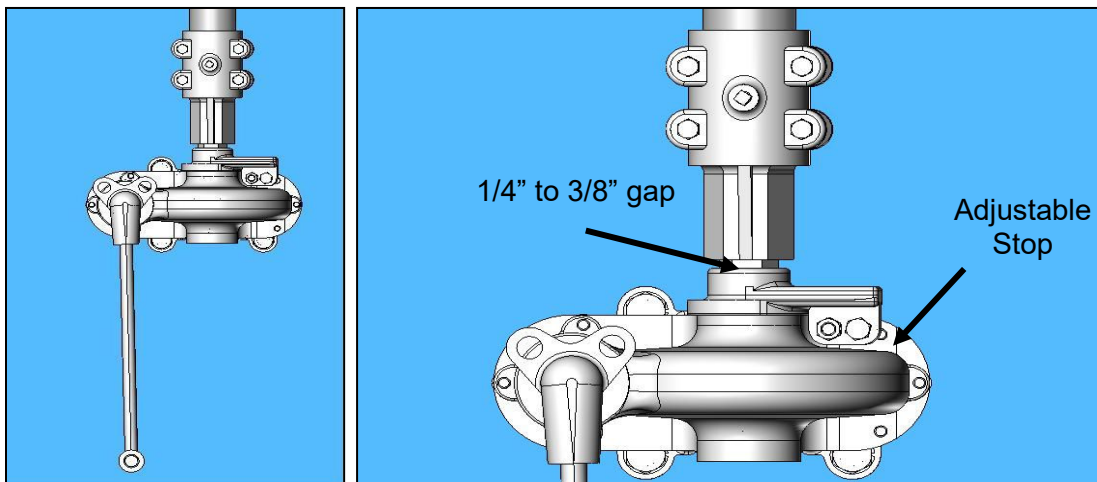
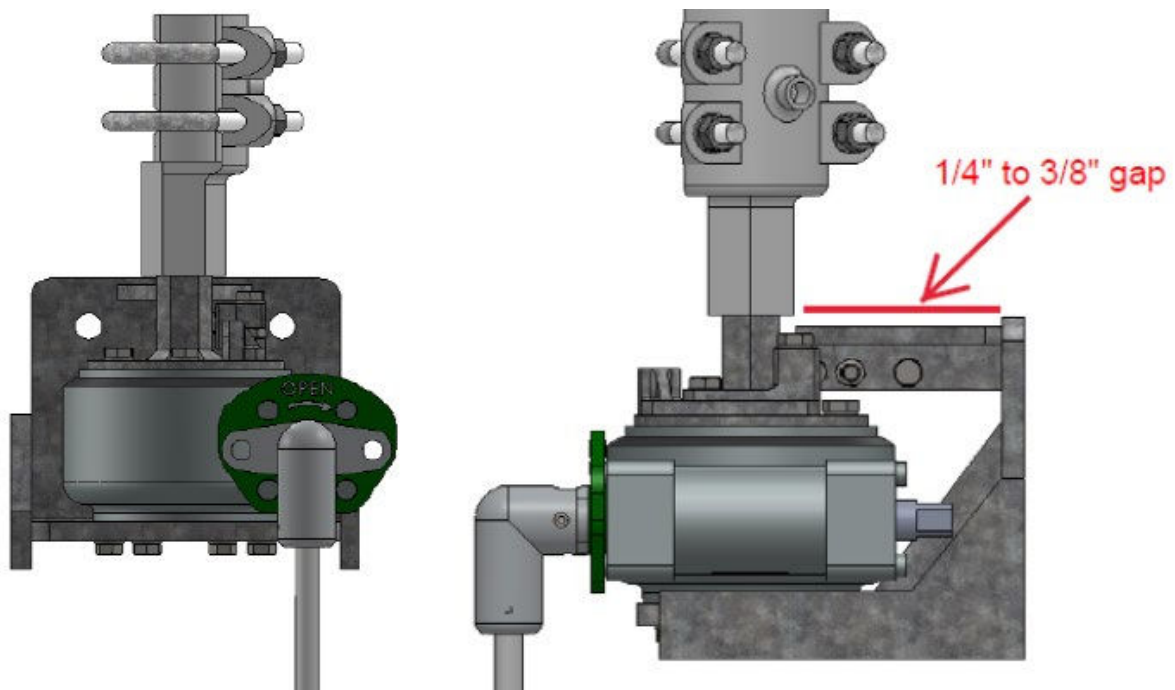

Figure 13: Type HOGO (High Output Geared Operator) Front View

## Installation & Adjustment Procedures

- 3.1. Worm gear operator (SEGO – Safety Enhanced Gear Operator) (Optional)
  - 3.1.1. The weight of the vertical operating pipe should be supported by pipe collar by maintaining the 1/4"-3/8" gap.
  - 3.1.2. When the switch is properly adjusted the operator handle should hang freely in both the open and closed positions to permit the use of the customer supplied padlock.

**⚠ CAUTION** Be aware that there is an adjustable stop on the operator. Do not over operate as damage will occur to the operator.



**Figure 14: Type SEGO (Safety Enhanced Gear Operator)**

- 2.3 Swing handle operator
  - 2.2.1. When the switch is properly adjusted the handle should hang vertically and free in both the open and closed positions to permit the use of a customer supplied padlock.
- 3.3 Electrical motor operator
  - 2.3.1. Please refer to motor operator instruction manual for proper installation and setup.
  - 2.3.2. Use manual operation while completing switch setup.
  - 2.3.3. **Do not** electrically operate until all switch adjustments are complete. **ALWAYS** operate the motor operator decoupled first to ensure proper setup.

## General Instructions for Threaded Clevises

### General Instructions for Threaded Clevises

When threaded clevises are specified, one is generally attached to the adjustable arm, and two more to the center phase switch arm (refer to the plan view of the operating mechanism drawing and the illustration below).

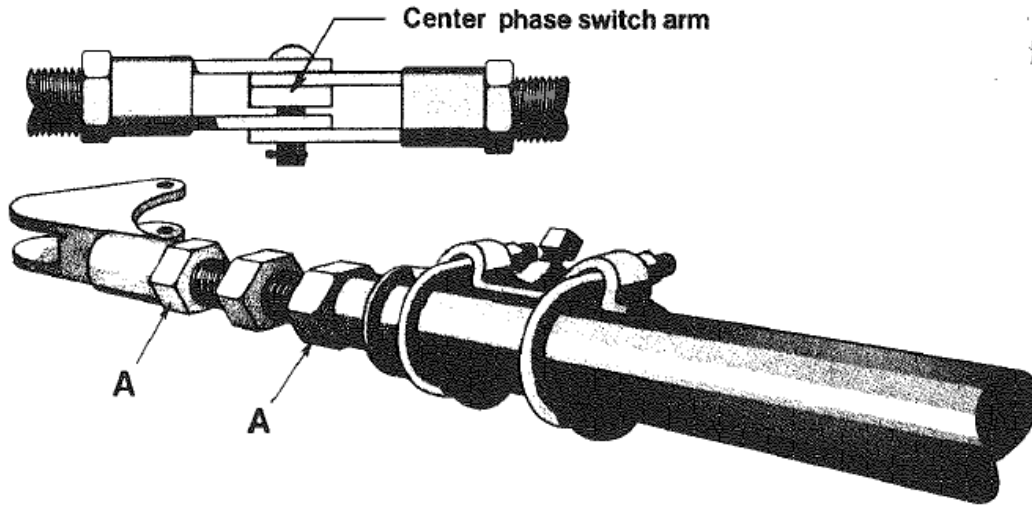

Operating mechanism adjustments consist mainly of incremental lengthenings and/or shortenings of the pipe that connect the switch arms together. To make these adjustments, simply loosen both jam nuts "A" and screw the stud in or out as required. Be sure to retighten both jam nuts securely.

**▲ CAUTION ▲ DANGER** Do not screw the stud out of the clevises. This could cause the pipe to fall, resulting in serious injury to personnel below.

Be sure the initial setting is correct, and do not adjust beyond the maximum allowable dimension. If adjustment beyond the maximum allowable dimension is needed loosen the U-bolts on the outboard phase clevis and reposition the pipe toward the center phase.

Initial dimension for  $\frac{3}{4}$ " stud is  $\frac{11}{16}$ "; 1" stud is  $\frac{1}{2}$ ".

Maximum allowable for  $\frac{3}{4}$ " stud is  $1\text{-}\frac{3}{16}$ ".  
Maximum allowable for 1" stud is 1".

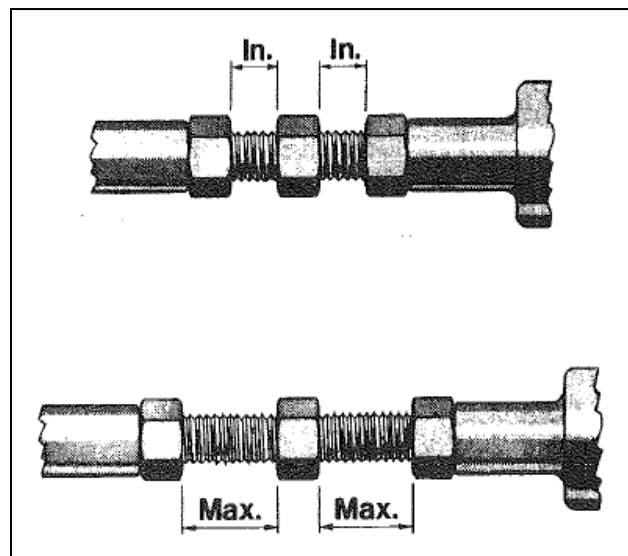

## Recommended Inspection Maintenance

### Recommended Inspection Maintenance

Southern States' disconnect switches are designed to operate with minimum maintenance. While disconnecting switches are not readily serviced at frequent intervals, *periodic inspection is important for satisfactory operation and maximized overall life*. Frequency of inspection and maintenance depends on the installation site, weather, atmospheric conditions, experience of operating personnel, and any special operation requirements.

During operational testing, the switch should be opened and closed several times, if possible, to clean the contacts and free the moving parts. A visual inspection, when the switch is wet, or temperature scanning detector may indicate hot spots that could serve as potential sources of trouble. Directional microphones or ultrasonic detectors can be used to locate local corona sources on the switches which can be eliminated during normal switch maintenance.

**NOTE**

It is recommended that maintenance on these switches be performed in accordance with ANSI STANDARDS **C37.30.1-2011**. In addition, well-established live-line servicing and maintenance procedures may be used in accordance with user practices and local and OSHA regulations.

Table 3: Recommended Installation and Maintenance Table

		Installation Tests	Patrolling Inspection 6-months	Routine 5 Year *	Periodic 10 Year *
<b>Insulators</b>	Contamination	X	X	X	X
	Damage	X	X	X	X
<b>Cabinet (if motor operator supplied)</b>	Any loose parts on the floor of the cabinet?	X	X	X	X
	Wiring Secure	X	X	X	X
	Links Secure	X	X	X	X
	Inspect Mechanism for loose parts	X	X	X	X
	Heaters Energized	X	X	X	X
	Door Seal	X	X	X	X
<b>Mechanical</b>	Operational Tests	X		X	X
<b>Electrical</b>	Contact Resistance	X		X	X
<b>Liveparts Inspection</b>	Inspect Contacts	X		X	X
	Inspect Arcing Horns	X		X	X

**\*NOTE:** Inspection/maintenance is suggested to be performed every two (2) years when installed in harsh environments with excessive airborne contaminants such as salt spray and industrial pollutants.

## Recommended Inspection Maintenance

### Patrolling Inspection (6 Months)

The patrolling inspection is a largely visual inspection on an energized unit in service. The frequency of the inspection is determined by the local conditions and policies of the owner of the equipment.

- Inspect the insulators for breaks, cracks, burns, or cement deterioration. Clean insulators particularly where abnormal conditions such as salt deposits, cement dust, or acid fumes exist to minimize possibility of a flashover.
- If an accompanying motor operator is supplied, check the cabinet for loose parts and ensure that all wiring is secure, the heater is energized, and the door is sealed.

### Routine Inspection and Maintenance (5 year)



The disconnect switch must be de-energized, disconnecting from all electrical power sources before servicing.

- Perform patrolling inspection (above), checking insulators and cabinet
- Once the disconnect switch is de-energized, test operate the switch multiple times.
- Check the switch for alignment, contact pressure, eroded contacts, corrosion, and mechanical malfunction, replacing damaged or eroded components if necessary. If contact pitting is minor, smooth the surface with a clean, fine sandpaper. It is recommended to clean and reapply C5-A grease during any operation or maintenance cycle, as exposed surfaces (*such as contacts*) are vulnerable to environmental conditions and contaminants that can decrease the effectiveness of the grease over time. During reapplication, clean and wipe down the contact surfaces with a green Scotchbrite pad, reapply C5-A grease, and remove any excess grease until an evenly coated, thin film is present.
- Inspect arcing horns for signs of excessive arc damage and replace if necessary.
- Check blade lock or latch for adjustment.
- Inspect all live parts for scarring, gouging, or sharp points that could contribute to excessive radio noise and corona. Check corona balls and rings for damage that could impair effectiveness.
- Inspect interphase linkages, operating rods, levers, bearings, etc. to assure that adjustments are correct, all joints are tight, and pipes are not bent.
- Check for simultaneous closing of all blades and for proper seating in the closed position.
- Inspect and check all safety interlocks while testing for proper operation.

### Periodic Inspection and Maintenance (10 year)



The disconnect switch must be de-energized, disconnecting from all electrical power sources before servicing.

- Follow instructions for 5-year Routine Inspection and Maintenance







**The Quality Name in High Voltage Switching**

30 Georgia Avenue  
Hampton, Georgia 30228  
Phone: 770-946-4562  
Fax: 770-946-8106  
E-mail: [support@southernstatesllc.com](mailto:support@southernstatesllc.com)  
<http://www.southernstatesllc.com>

©2021 Southern States, LLC  
IB-132-CBL-T 72.5- R6 02182021 Printed U.S.A.