

Transmission Switching



The Power of Ideas

GENERAL APPLICATION

Southern States supplies a wide offering of Transmission Switching solutions in response to an increasing need for improved system reliability and reduced installation times. This range of solutions spans from a fairly basic group operated disconnect switch to building a customized “Substation in the Sky.”

The ES-1, 1-way, 2-way, and 3-way phase-over-phase side break switches offer an easy to install solution for isolation and sectionalizing of loop and radial transmission lines. These configurations are often used in restricted right-of-ways where a substation is too expensive or transmission network sectionalizing is desired.

Southern States now offers unitized designs for the vast majority of switch types. Unitized switches consist of all three phases, assembled and adjusted on a base, to speed up installation and simplify adjustments after mounting on the transmission line pole. Both the ES-1 and unitized switches are available with a full complement of accessories, operators, and interrupter attachments including the single gap, **LLS**® Load Break Interrupter.

Recent innovations for Transmission Line Switching include **Smart Tap**® enabled **T-FDIR** and the “Substation in the Sky.” Information on these unique solutions can be found at the conclusion of the bulletin.

Transmission Switching



15 - 362 kV
1200 - 4000 A

ES-1 PRODUCT FAMILY

Through Southern States’ research and development, understanding of existing issues, and integration of user feedback, the ES-1 family was designed to provide a reliable, quality product that resolves many of the common issues experienced by one-way and multi-way transmission disconnects.

The unique blade design with jaw end pivot produces a very low operating effort, eliminating concerns of operator dependent force requirements on closing. By shipping the phases assembled on a platform, the switch is easy to install and requires minimal adjustment.

The design is also compatible with the only single gap, Load Break Interrupter (**LLS**[®]) available through 145 kV.

FEATURES

- Unique live parts that require very low operating effort
- Trouble free contact alignment
- Shipped fully assembled and adjusted
- Quick and simple installation process (unfold/lift to install)
- Proven SF₆, single gap, **LLS**[®] interrupters for worry-free switching under all conditions



RATINGS			
Max Voltage, kV	72.5	123	145
BIL, kV	350	550	650
Rated Power Frequency	60 Hz		
Continuous Current	1200 & 2000		
Short-time Withstand, 3 sec, kA	38 & 63 kA RMS		
Peak Withstand, kA	99 & 164 kA		
Ambient Temperature Rating	-40°C to +50° Standard -50°C Optional		

SWITCH OPTIONS	
ACCESSORIES	OPERATORS
<ul style="list-style-type: none"> • AVS-1 • Mechanical Interlock • Electrical & Key Interlocks 	<ul style="list-style-type: none"> • VM-1 Motor Operator • HOGO

SWITCH INTERRUPTER ATTACHMENTS				
PRODUCT	LOAD BREAKING	LOOP SPLITTING	LINE/CABLE DROPPING	TRANSFORMER MAGNETIZING
Standard Arcing Horn			X	X
Quick Break Whip			X	X
High Speed Whip			X	X
LLS [®] -I	X	X	X	X
LLS [®] -II	X	X	X	X

ES-1 STANDARD DESIGN FEATURES

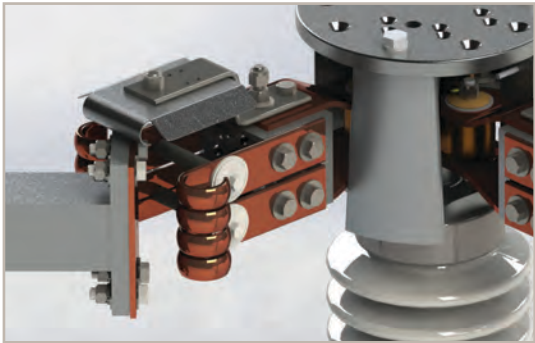

LIVE PARTS

- Reduced operating force due to unique blade design with jaw end pivot
- Contacts cleaned by sliding action during opening and closing
- Positive latching not dependent on operator closing speed
- Blade is not spring biased, removing the chance for mis-operation
- Oversized contact bar reduces impact of blade leveling to properly seat the contacts
- Aluminum/copper or all copper live parts available based on customer preference

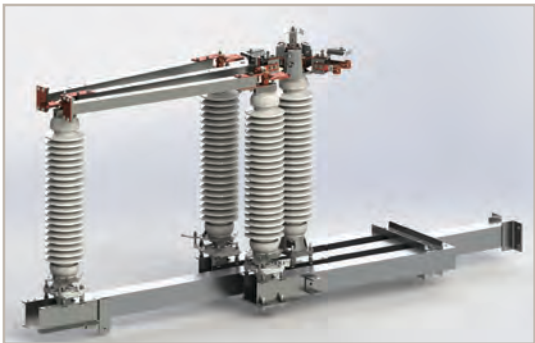

FRAME

- Collapsible frame allows for reduced shipping costs
- Reduced installation time as each phase is fully assembled on insulators
- Two and three-way collapsible frame reduces installation time
- Low closed profile frames reduce deflection and can take large pull-off



OPERATING MECHANISM

- Pipe diameter and gauge sized to eliminate torsional deflection
- Adjustable controls on each phase simplifies three phase alignment
- Leveling bolts on each insulator for ease of contact alignment
- Robust design provides smooth, controlled operation while switching



CUSTOM DESIGN BENEFITS

- Over 100 years of custom engineered products designed to meet customer needs
- Capable of integrating a variety of accessories and interrupting devices including the single gap, SF₆ **LLS**[®] Load and Line Interrupter Switch attachment
- Full engineering team to adapt equipment to existing structure and specification

ONE WAY CONFIGURATIONS

Phase Opposite Phase

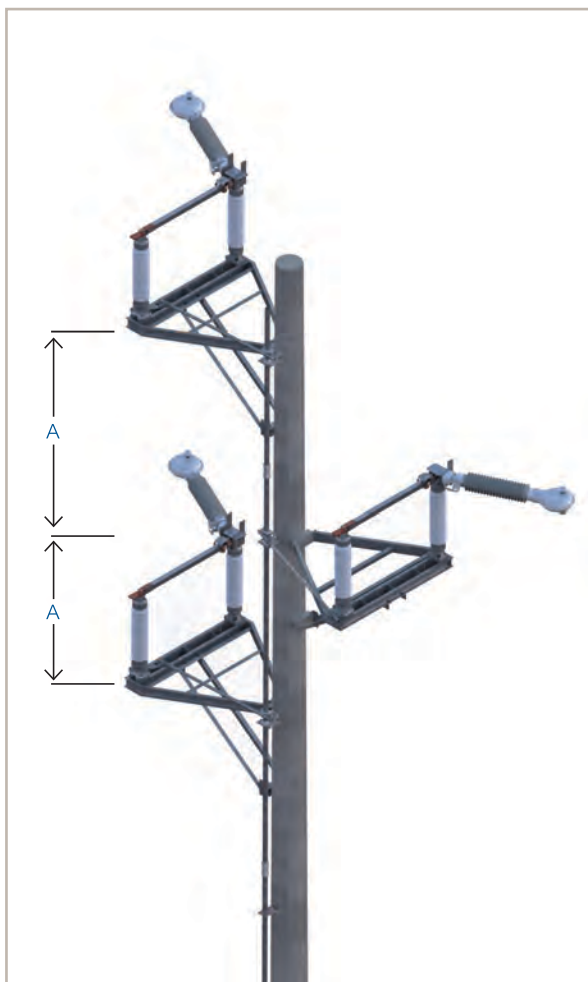
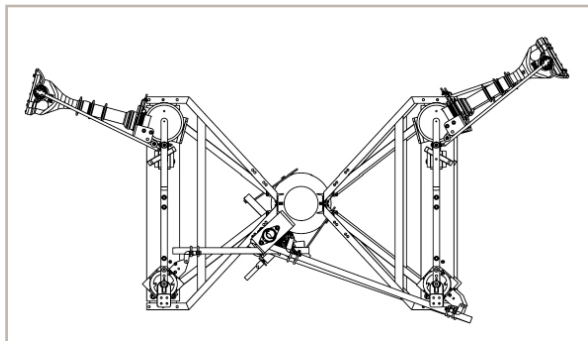

Voltage	Min "A" Dim
72.5 kV	4.5'
123 kV	5.5'
145 kV	6'

In-Line Phase Over Phase

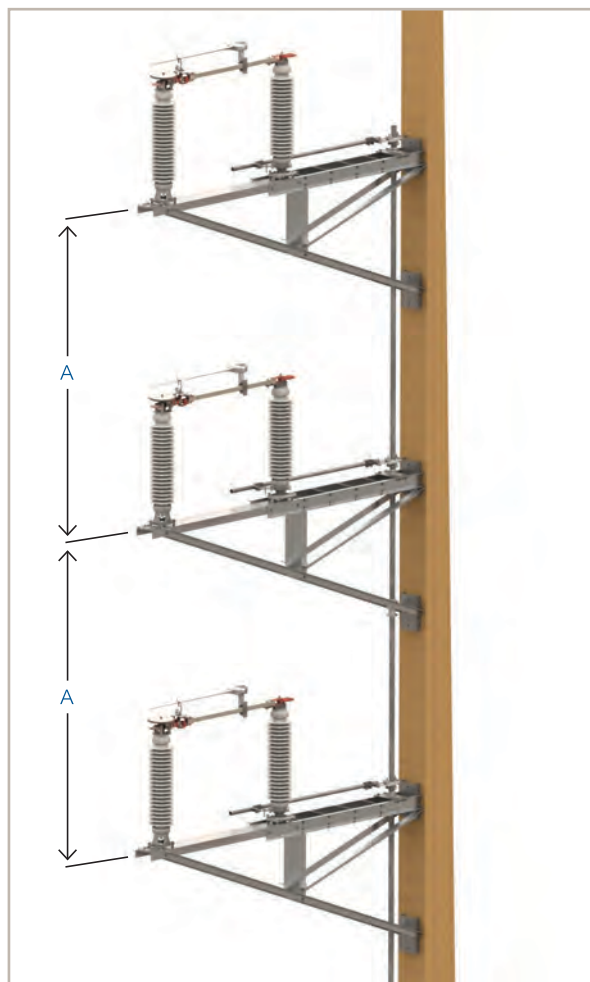
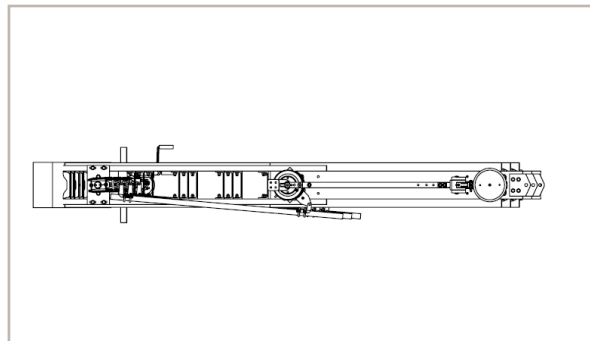

Voltage	Min "A" Dim
72.5 kV	10'
123 kV	12'
145 kV	13.5'

ONE WAY CONFIGURATIONS

Delta

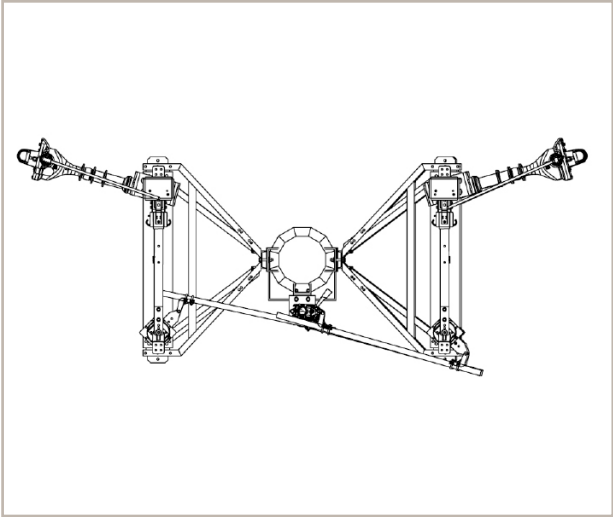

Voltage	Min "A" Dim
72.5 kV	9'
123 kV	11'
145 kV	12'

Phase Over Phase

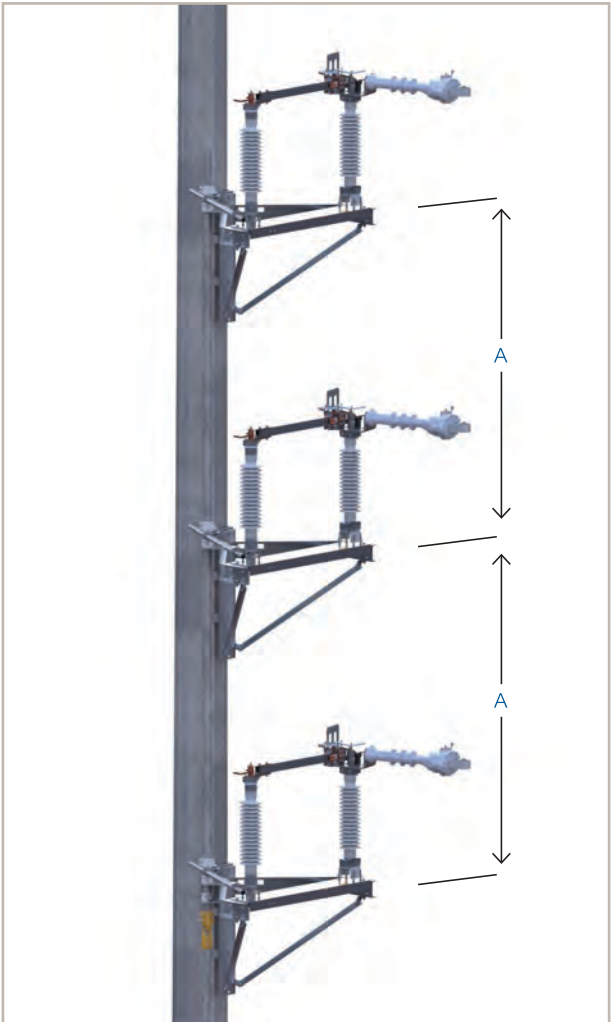
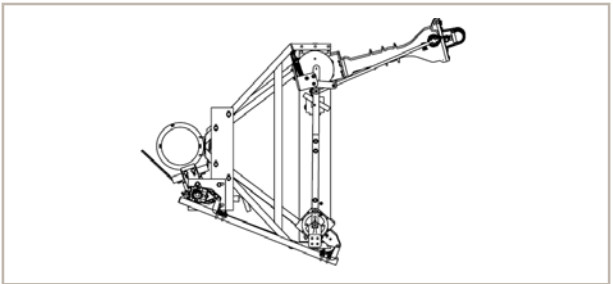

Voltage	Min "A" Dim
72.5 kV	9'
123 kV	11'
145 kV	12'

TWO WAY CONFIGURATIONS

Two Way

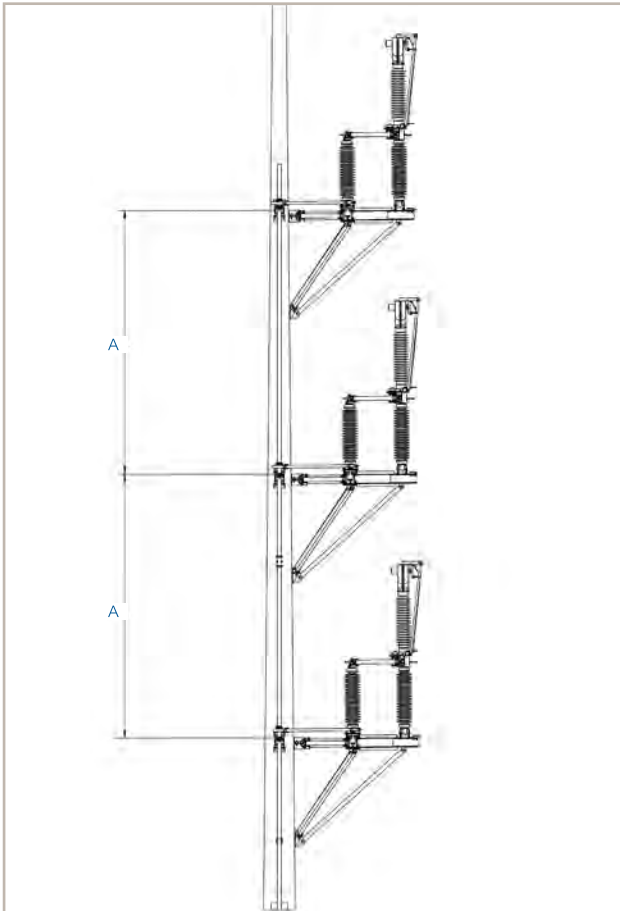
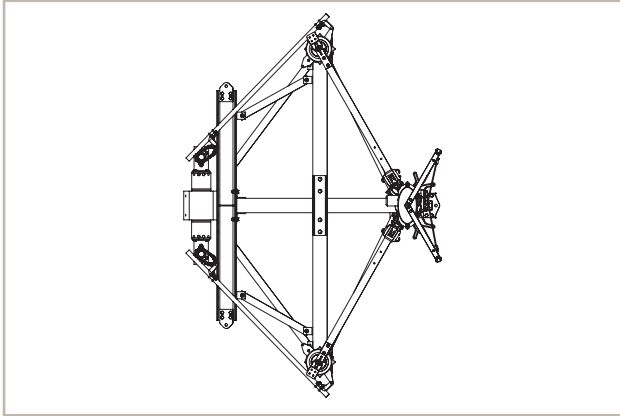

Voltage	Min "A" Dim
72.5 kV	8'
123 kV	12'
145 kV	13'-6"

THREE WAY CONFIGURATIONS

Three Way

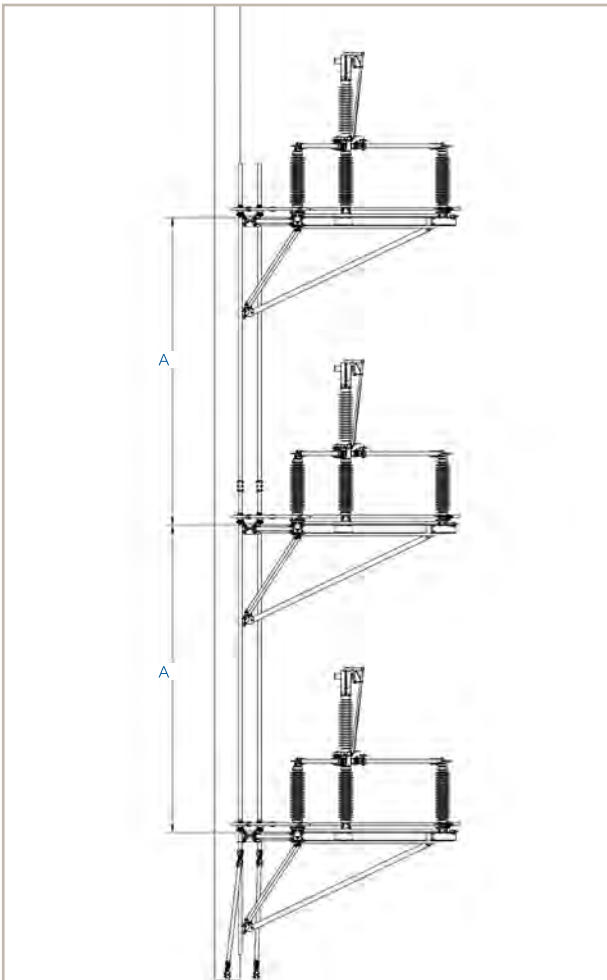
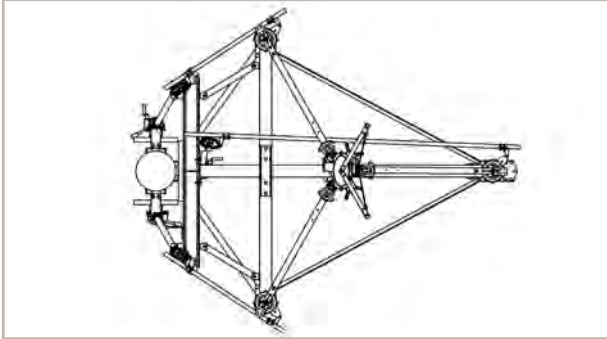

Voltage	Min "A" Dim
72.5 kV	9'
123 kV	13'
145 kV	14'-6"

UNITIZED DISCONNECT SWITCHING

Southern States offers a complete line of unitized disconnect switching solutions to satisfy a variety of market applications. Fully assembled and adjusted from the factory, customers experience reduced costs associated with quick installation times and simplified field assembly and adjustment. The unitized EV-2 and EC-1V have provided solutions for numerous market applications and offer valuable, minimized phase spacing. Attachments, such as the **LLS®-I**, and accessories are also available for these unitized offerings.

FEATURES

- Horizontal or side mount mounting arrangements
- Configurations available for all switch types
- Easily accommodates full load break interrupters and other accessories
- Three-sided NEMA terminal pads for easy conductor terminations
- Reduced installation time



RATINGS

Maximum Voltage Rating (kV)	15.5	27	38	48.3	72.5	123	145	170	245	362
BIL (kV)	110	150	200	250	350	550	650	750	900/1050	1050/1300

ADDITIONAL RATINGS

Rated Power Frequency	60 Hz	
Continuous Current	1200 A - 3000 A	4000 A
Short-Time Symmetrical Withstand (3 Sec)	63 kA RMS	80 kA RMS
Peak Withstand	164 kA	208 kA
Ambient Temperature Rating	-40°C to +50° Standard / -50°C Optional	

SWITCH INTERRUPTER ATTACHMENTS

PRODUCT	LOAD BREAKING	LOOP SPLITTING	LINE/CABLE DROPPING	TRANSFORMER MAGNETIZING
Standard Arcing Horn			X	X
Quick Break Whip			X	X
High Speed Whip			X	X
LLS®-I	X	X	X	X
LLS®-II	X	X	X	X

SWITCH OPTIONS

ACCESSORIES

- AVS-1
- Mechanical Interlock
- Electrical & Key Interlocks

OPERATORS

- VM-1 Motor Operator
- HOGO

UNITIZED STANDARD DESIGN FEATURES

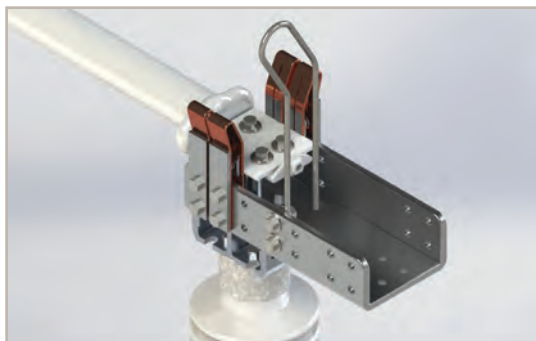

LIVE PARTS/CONTACTS

- Reverse loop design
- Wiping action
- Silver to silver surfaces using two different silver alloys
- Heavy duty mechanism
- Long life and suitable for high mechanical loads



BASE

- Sealed and permanently lubricated double row stainless steel ball bearings
- Double channel construction above 72kV
- Galvanized steel - Aluminum optional



OPERATING MECHANISM

- Available with swing handle, worm gear operator or motor operator
- Available with clamp type or optional threaded type linkage fittings
- Easy and fast installation and adjustment
- Interphase and phase drive arms are pre-installed and adjusted at factory



EFFICIENT DESIGN

- Single pick installation
- Highly reduced installation time
- Minimal field assembly and adjustment
- The pole units (all three phases) are delivered fully adjusted and assembled on frame with outboard bearings, clevises, and reach pipes

UNITIZED EV-2

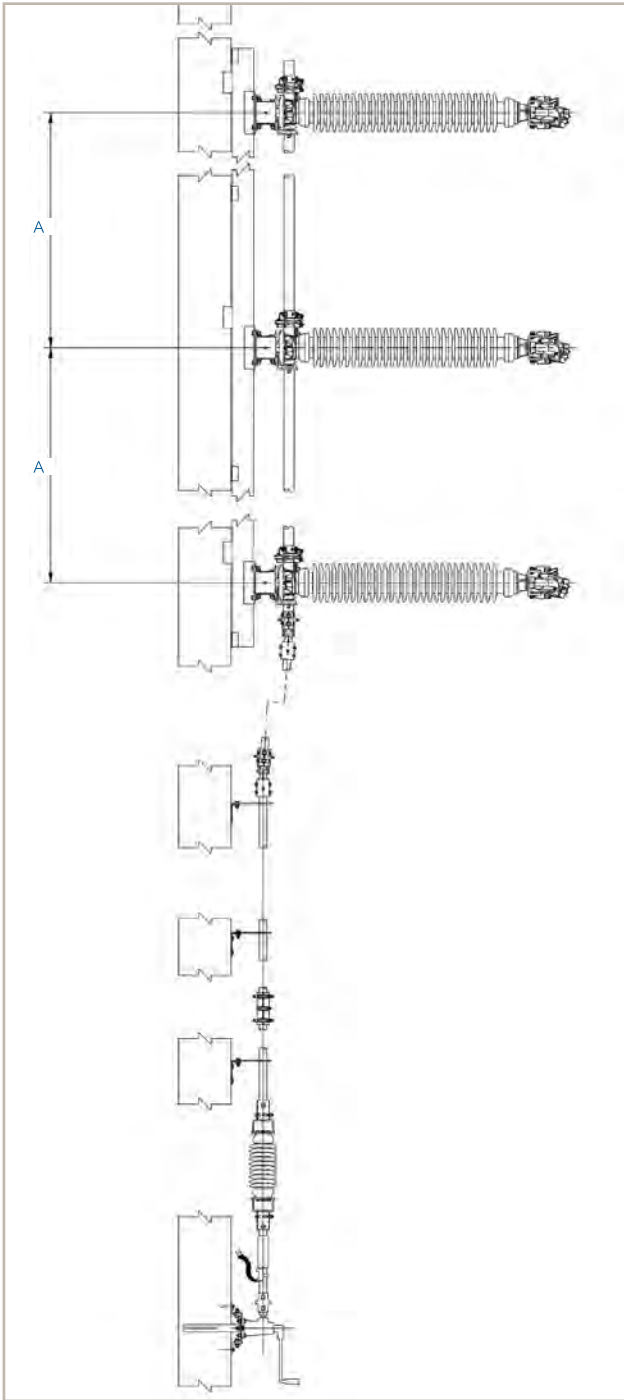

Voltage	Min "A" Dim
72.5 kV	5'
123 kV	7'
145 kV	8'
170 kV	9'
245 kV	11'

UNITIZED EC-1V

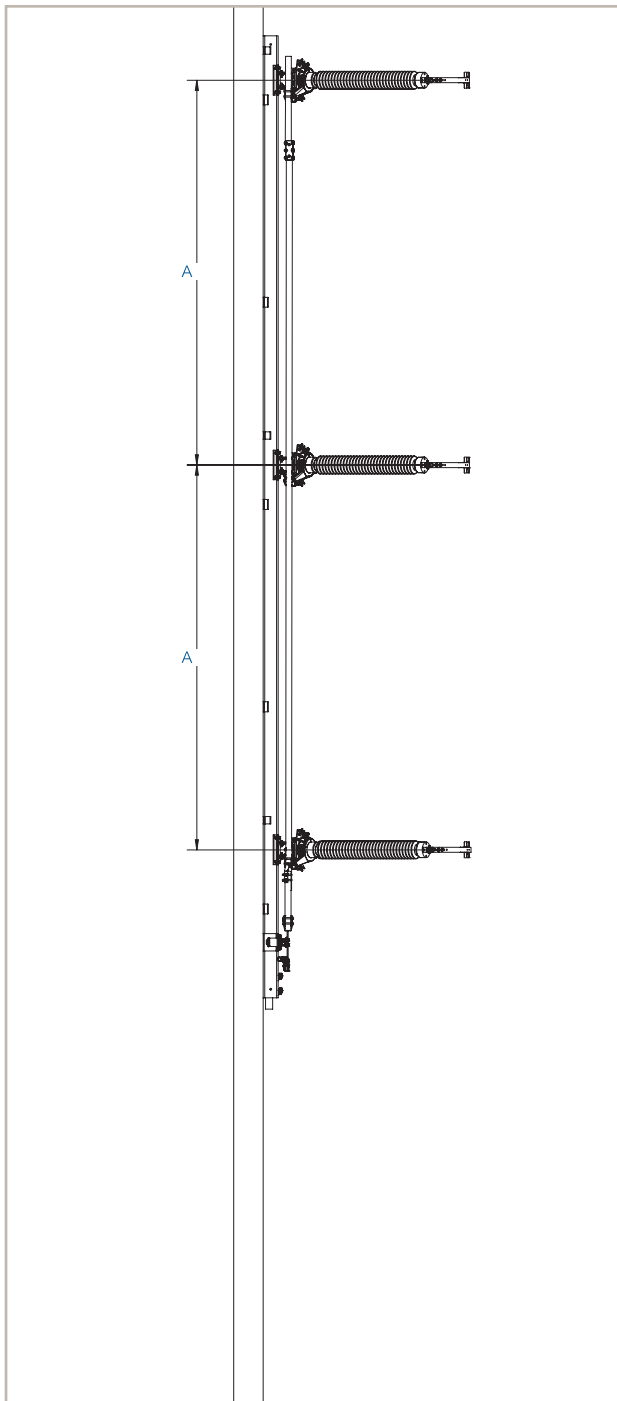

Voltage	Min "A" Dim
72.5 kV	6'
123 kV	8'
145 kV	9'
170 kV	10'
245 kV	13'

INTEGRATED SOLUTIONS

For unique transmission application challenges, Southern States offers specialized solutions. Substation in the Sky is a totally customized application, addressing system protection, sectionalizing, and isolating needs of our customers. Equipment can be tailored to meet a wide range of applications. The Substation in the Sky offers the ability to monitor, communicate system information, and switch transmission lines and taps. When space is at a premium, Southern States can engineer a more economical solution than the traditional practice of building a small substation.

FEATURES

- Custom engineered for each application
- Multiple voltage and current sensing options
- Wide selection of products for line isolation and equipment bypass
- Fault or load interrupting devices selected based on application
- Communication systems matched to customer specifications



SUBSTATION IN THE SKY

SWITCHING EQUIPMENT

Category	Product	Rating
Power Switching	CSV	48.3 – 242 kV
	CSH	38 – 245 kV
	CapSwitcher®	15.5 – 145 kV
Disconnect Switching	EV-2	15.5 – 362 kV
	PBO (PBO -1)	8.3 – 170 kV
	RDA -1	38 – 362 kV
	EC-1 (EC-1V)	38 – 245 kV

COMMUNICATIONS

- SEL relays
- Battery Cabinets (Chargers)
- Wireless Routers
- VM-1
- AVS-1
- Electroswitch
- Others (per request)

MONITORING

- **ICS®** platform (**Smart Tap®/ Smart Trip®**)
- CT
- PT

CONFIGURATIONS

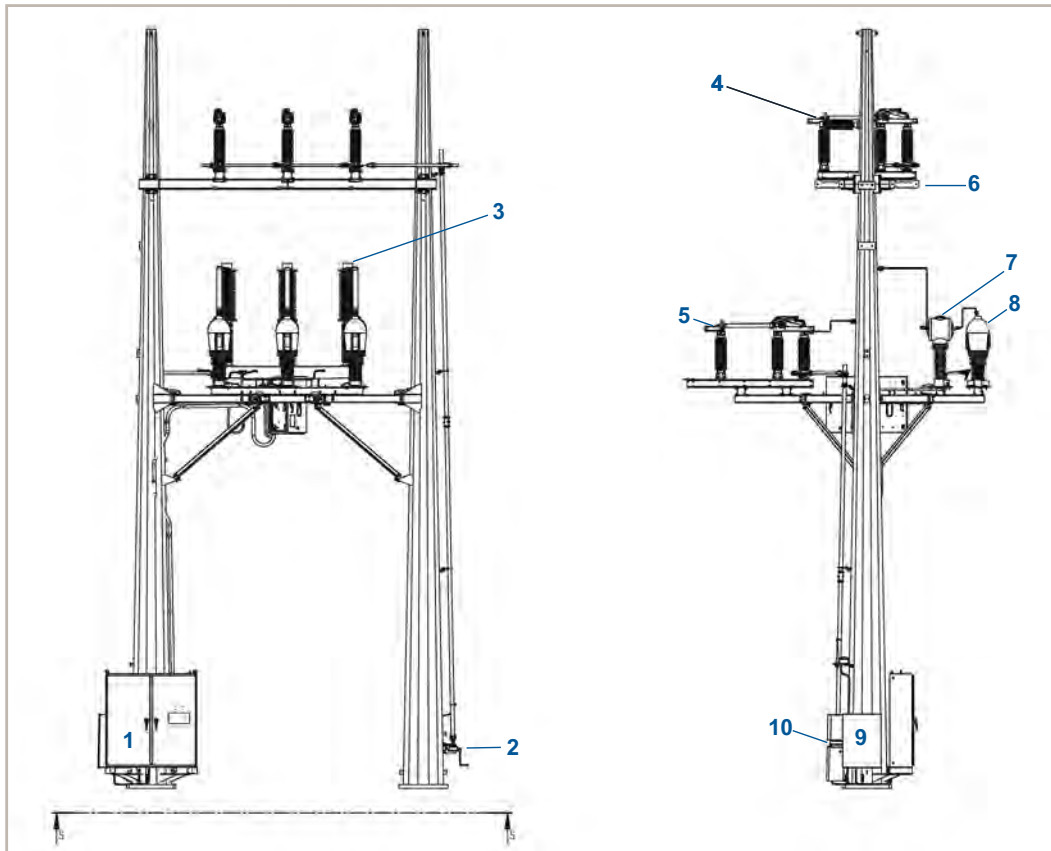

Configuration # 1

1. Main Control Cabinet
2. Gear Operation for Bypass
3. CSV
4. Bypass Switch
5. Air Disconnect
6. Vang Mounting
7. CT Assembly
8. PT Assembly
9. Battery Cabinet
10. VM-1 Motor Operator
(for air disconnect)

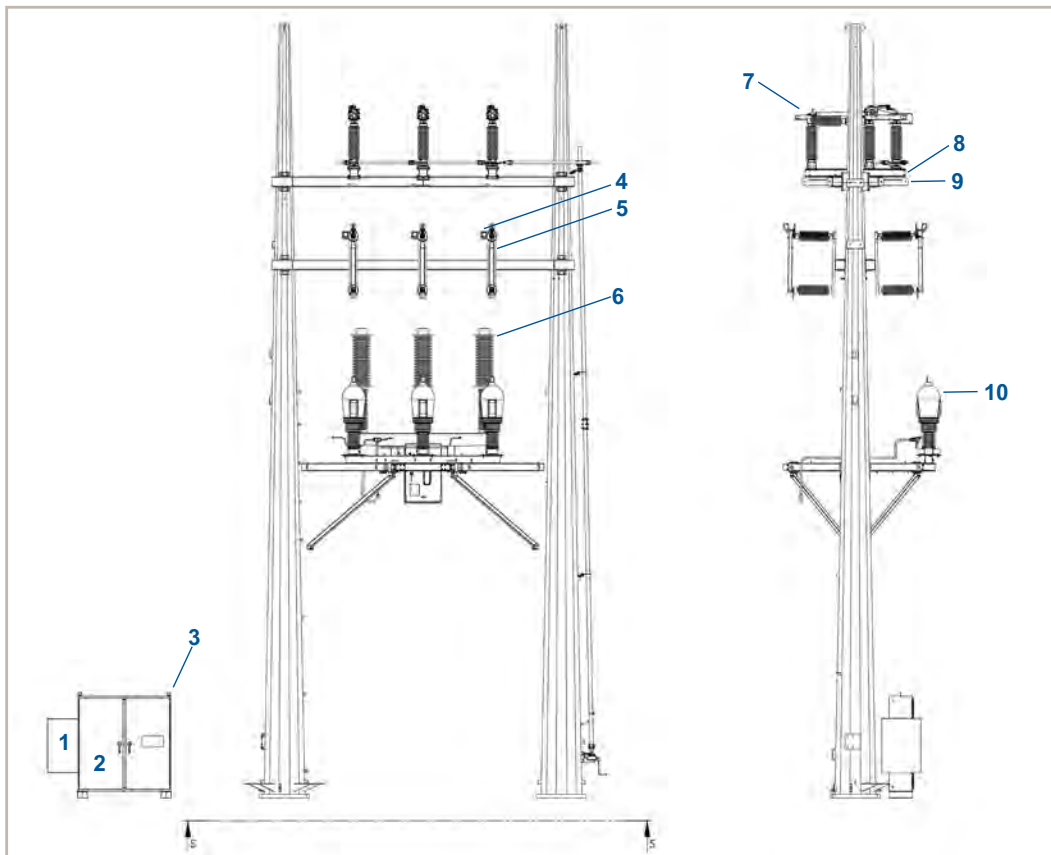

Configuration # 2

1. Battery Cabinet
2. Main Control Cabinet
3. Antenna
4. Arrestor
5. PBO
6. CSV
7. Bypass Switch
8. Line Vang
9. Vang Mounting
10. PT Assembly

TRANSMISSION FAULT DETECTION,
ISOLATION & RESTORATION

Addressing the need for smarter, more reliable transmission line networks, Southern States has developed automated solutions that can drastically reduce the scope and duration of an electrical outage by enhancing existing breaker reclosing capabilities to sectionalize transmission lines within the breaker reclosing cycle. This creates significant value for utilities, who must adhere to stringent reliability measures, such as SAIFI, SAIDI, and CAIDI. In doing so, they can avoid significant lost revenues, regulatory penalties, as well as end-user dissatisfaction.

The Southern States zone based, T-FDIR solution is built on two innovative technologies: the **ICS**[®], an intelligent circuit sensor that provides real time current and voltage, and **Smart Tap**[®], a software platform that interprets the **ICS**[®] output and provides fault direction and distance information.

T-FDIR utilizes the real time fault direction and distance information to operate switches, when the line is de-energized, to isolate the faulted section. This allows the breaker to successfully restore power to the unaffected areas. T-FDIR is a no-risk solution, never closing switches into a faulted line segment or opening switches on an energized line. This solution eliminates traditional trial and error approaches that are often complex, less efficient, and result in wider area and longer outages. T-FDIR requires no operator action and can be accomplished within thirty to sixty seconds after an instantaneous reclose fails. This self-healing process can help to drastically reduce customer interruption duration and, as a result, their reportable reliability figures.

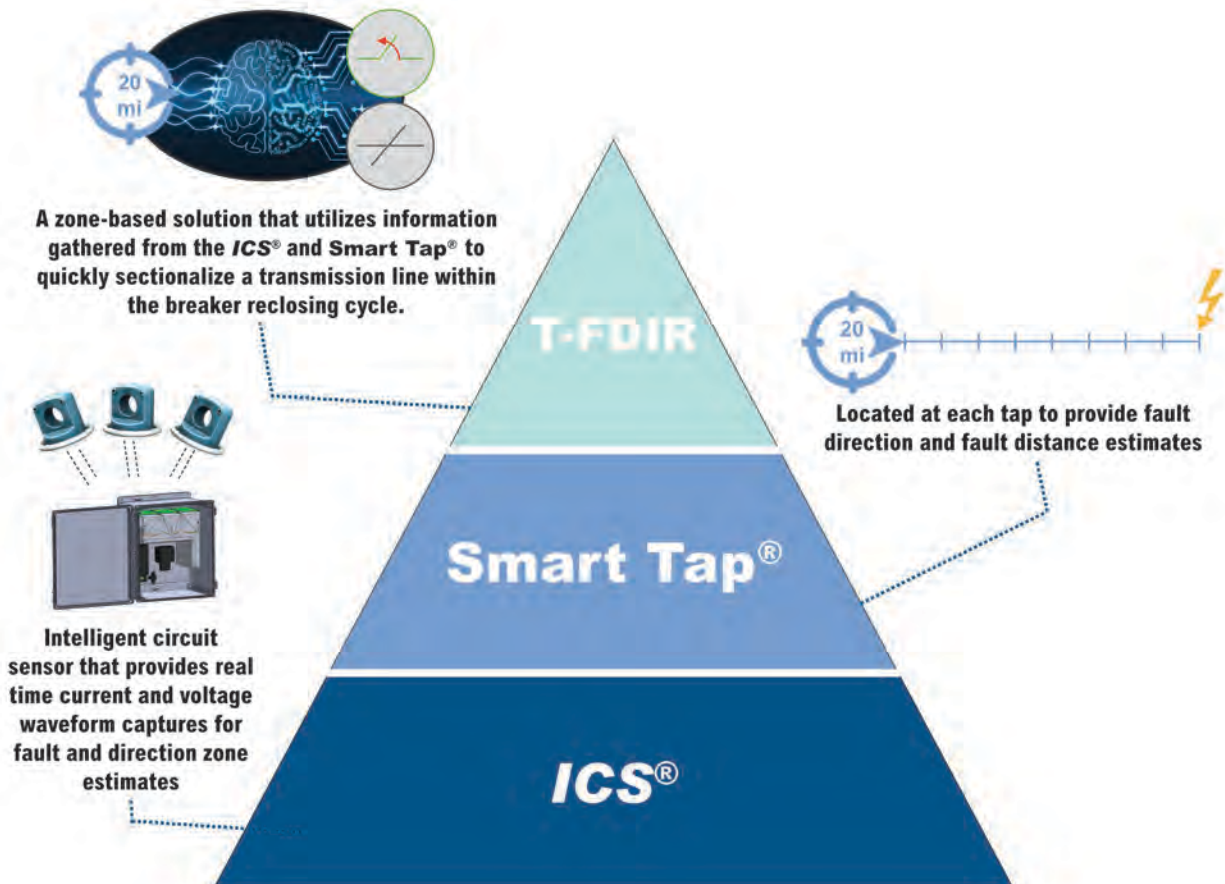
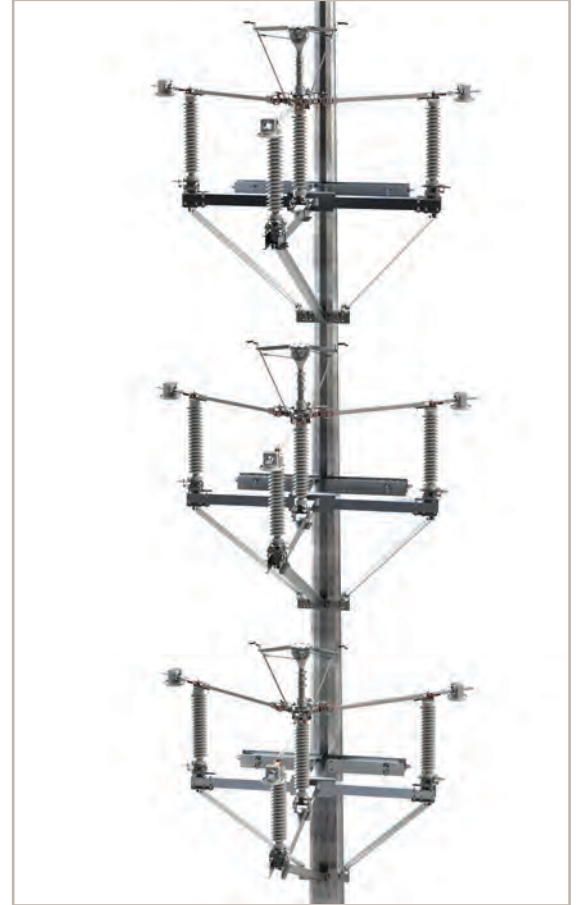

FEATURES & BENEFITS



ICS® & Smart Tap®

- Wireless sensor
- 2.4 GHz radio from sensor to base
- No batteries and maintenance
- Environmentally sealed for life
- Zero footprint - can be mounted on overhead structures
- No communication to control center or to other taps required
- Provides fault direction to establish faulted zone categories
- DNP 3.0 for communication to control center SCADA
- Minimal investment per node

RATINGS & SPECIFICATIONS

ICS® and Smart Tap®

Current / Voltage Sensing	Southern States ICS®
Sensor Assembly	Environmentally sealed for life, no maintenance
Sensor Power Supply	Self-energy harvesting, no batteries
Wireless Sensor Transmitting	2.4 GHz radio from sensor to base
Current/Voltage Sampling Rate	32 Current / 16 Voltage samples per cycle
Applicable Voltages	to 362 kV
Continuous Current	3000 A
Sensor Startup Time	< 10 ms
Sensor Startup Current	10 - 12 A
Current Accuracy	Magnitude: +/- 1.0%; Angle: +/- 0.5 Degree
Communications	DNP3/Modbus through Serial/TCP/IP
Temperature Range	-40°C to +85°C
Power Supply	24, 48, 100 VDC or 110 VAC



30 Georgia Avenue, Hampton, GA 30228
P 770.946.4562 F 770.946.8106
sales@southernstatesllc.com www.southernstatesllc.com
24/7 emergency support line: 770.946.4565