

NOTE:-- CLEAN BOTH CONNECTING SURFACES OF TERMINAL PADS AND TERMINAL FLANGE WITH SAND PAPER AND COAT SUPPLIED COMPOUND BEFORE CONNECTING.

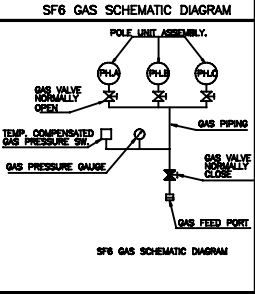
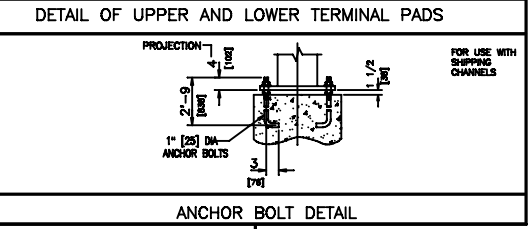
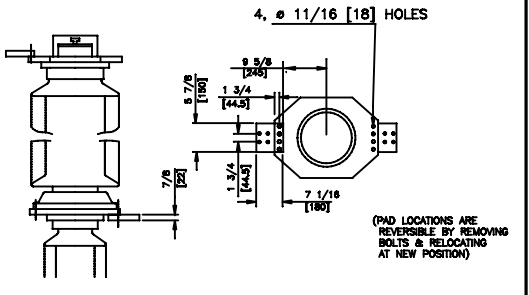
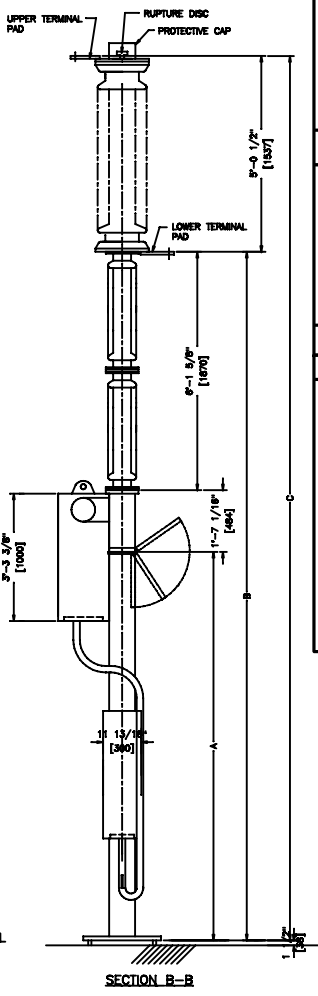

DIMENSIONS IN INCHES (APPROX.)

| A | B | C |
|------------------|------------------------|------------------------|
| STRUCTURE HEIGHT | LOWER TERM. PAD HEIGHT | UPPER TERM. PAD HEIGHT |
| 96 [2438] | 188 1/4 [4782] | 248 3/4 [6265] |
| 120 [3048] | 212 11/16 [5402] | 273 1/8 [6938] |
| 144 [3658] | 236 1/4 [6001] | 296 3/4 [7537] |

TERMINAL PAD LOADING

| DIRECTION OF LOAD | LOADING, LBS | LOADING, KG |
|--------------------------------|--------------|-------------|
| IN-LINE WITH TERMINAL PADS | 281 | 127 |
| PERPENDICULAR TO TERMINAL PADS | 108 | 76 |
| VERTICAL TO TERMINAL PADS | 225 | 102 |

PROPOSAL DRAWING

NOT FOR CONSTRUCTION
SPECIFICATIONS SUBJECT
TO CHANGE

THIS DRAWING AND THE INFORMATION HEREIN ARE THE PROPERTY OF SOUTHERN STATES, LLC AND ARE PROVIDED FOR THE EXCLUSIVE USE OF OUR CUSTOMERS, SUPPLIERS AND VENDORS. THE DRAWING OR INFORMATION IS NOT TO BE REPRODUCED OR COPIED BY ANY OTHER PARTY WITHOUT THE SPECIFIC WRITTEN APPROVAL OF SOUTHERN STATES, LLC.

Southern States, LLC
2000 W. 10TH AVENUE
DENVER, CO 80202
TEL: (303) 441-3100

PROPOSAL OUTLINE
CSV 161-169 KV
84" PHASE SPACING
(40 KA, -40C)

| DATE | BY | APP. BY | DESCRIPTION |
|---------|-----|---------|-----------------------|
| 6/18/07 | PVP | | PROPOSAL |
| | | | SHEET NO. 1 OF SHEETS |
| | | | PD-CSV 161-169 KV_B4 |