

Local, Series-Connected Interrupters Enhance System Reliability

Larry Taylor, P.E., Charles Shih, P.Eng., and Tom Speas

Abstract—Circuit switchers are designed for, tested, and used in substation protection schemes to clear transformer internal faults as well as back-up protection of the transformer secondary circuits. If the circuit switcher fails to successfully clear the fault, it is common for a circuit breaker, upstream from the substation, to perform the interruption. The utility may use a distance relay scheme, a transfer trip scheme, or a scheme that introduces a local, fault initiation device, such as a high-speed ground switch. This paper provides case studies from two utilities where local, series-connected interrupters are used to reduce the likelihood that transmission breakers will be required to open, thus increasing the reliability of the system and reducing customer outages.

I. INTRODUCTION

Circuit switchers are utilized as the primary protection devices in transformer protection schemes in many substations today. A typical protection scheme is to use a differential relay for protection of the transformer and sometimes the whole substation dependant upon the zone of protection chosen. It is also common to utilize overcurrent relaying (phase & ground) as back-up protection for the transformer. Several types of equipment alarms are used in conjunction with these relays for protection (aka winding temp, loss of dc, oil temp alarms, etc....).

If any of the above mentioned devices detect a fault requiring that the station or transformer be taken off line, the circuit switcher is asked to operate and clear the fault. To improve reliability, many utilities have implemented a “breaker failure” scheme that is initiated if the circuit switcher does not open or fails to clear the fault. The schemes used most often include: a distance relay scheme, a transfer trip scheme, or a scheme that uses a fault initiation switch. A fourth option using local, series-connected interrupters (circuit switchers) has been successfully applied by SaskPower and Middle Tennessee Electric MTEMC. This paper provides case studies for the series-connected interrupters as applied by these two utilities.

Larry Taylor is a substation electrical engineer at MTEMC, Murfreesboro, Tennessee; larry.taylor@mtmc.com

Charles Shih is the Engineering Supervisor, Substation, Lines and Stations for SaskPower, Regina, Saskatchewan, Canada; cshih@saskpower.com

Tom Speas is the Sales and Marketing Manager for the Power Switching Division of Southern States, LLC in Hampton, Georgia; t.speas@southernstatesllc.com.

II. CASE STUDY #1

SaskPower

As the principal supplier of electricity in Saskatchewan, SaskPower serves more than 451,000 customers. SaskPower operates three coal-fired power stations, seven hydroelectric stations, four natural gas stations and two wind facilities with an aggregate generating capacity of 3,214 megawatts (MW). SaskPower maintains more than 155,000 kilometers of power lines, 52 high voltage switching stations and 175 distribution substations.



Saskatchewan is a province in Canada that has an area of 588,276.09 square kilometers (227,134.67 sq mi) and a population of 1,010,146 (according to 2008 estimates), mostly living in the southern half of the province.

The size of the province dictates that many of the substations have long feeder lines and the loss of a line would inconvenience a large number of customers.

Below is a one-line for the Stoughton 802 Substation which is typical for the SaskPower system. The substation is tapped from a transmission line at a point that is 67 km (46 miles) from one switching station and 48 km (30 miles) from another switching station.

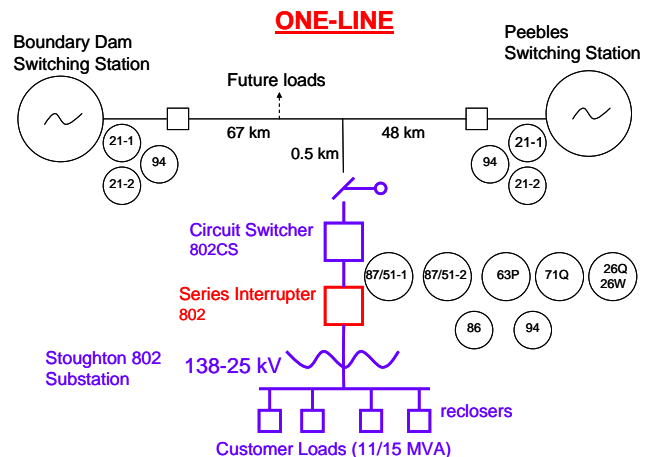

SaskPower has evaluated the use of distance relays, transfer trip schemes, and local fault initiation protection schemes for “breaker fail” backup protection for the transformer and substation protective device (circuit switcher).

It was determined that distance relays could not provide adequate back-up protection if the local circuit switcher would fail to interrupt a transformer fault. In the analysis below, it is clear that a 25 kV fault at the Stoughton transformer would not be seen by Zones 2 & 3. Both the Boundary Dam (BD) and Peebles relays would under-reach.

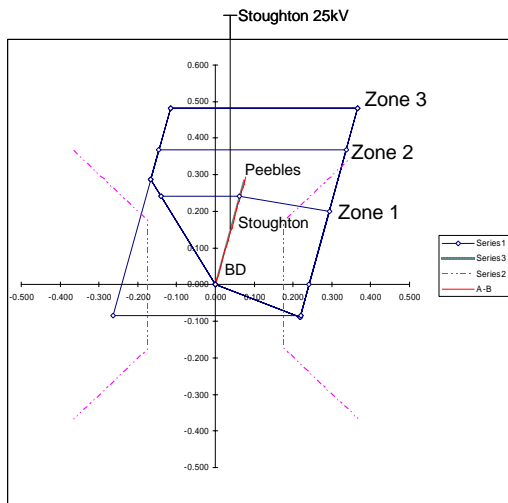

A distance relay is said to under-reach when the impedance presented to it is apparently greater than the impedance to the fault. This is due to the effect of fault current infeed from a remote station.

Relay setting = $Z_A + Z_C$

Relay actual reach = $Z_A + [I_A / (I_A + I_B)] \times Z_C$

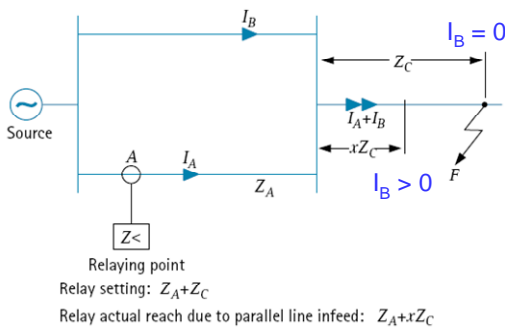

Under-Reach – Effect of Remote Infeed

The cost of adding fibre optic communications as part of a transfer trip scheme to the Boundary Dam and Peebles stations was cost prohibitive. While the use of a power line carrier would be less expensive it was felt that the reliability of the connection would be an issue. It was also determined that the use of a high speed ground switch to initiate an intentional fault was an undesirable solution due to the long term impact of intentionally initiating a ground fault on the system.

This analysis led to the use of local, series-connected interrupters, operating independently, where both circuit switchers would operate under any fault condition to clear the fault. The approach substantially increases the probability of a successful fault interruption at the local substation. It also decreases the likelihood that there will be a transmission line outage event, thus reducing customer outages.

Stoughton 802 Substation

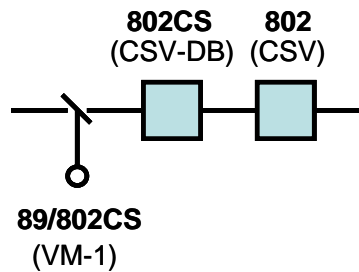

Operation

- 802 and 802CS trip independently upon operation of 86 or 94 protective relays. Both interrupters are 3 cycle devices.
- 89/802CS motorized disconnect switch will open via a 52b contact after the 802CS has opened.
- Closing of 802CS will initiate closing of the disconnect switch first. After the disconnect switch is closed, the auxiliary contact, located on the disconnect switch vertical pipe will initiate closing of the 802CS.
- 802 will be closed by local control.

Pelican Narrows Substation

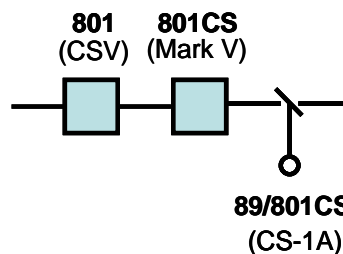

Operation

- 801 and 801CS trip independently upon operation of 86 or 94 protective relays.
- 801CS is an 8 cycle device. 801 is a 3 cycle device.
- 89/801CS motorized disconnect switch (CS-1A motor operator) will open via the 62X contact about 9 cycles after the protection operation and 801CS has tripped.
- 801 and 801CS will be closed by local control.

III. CASE STUDY #2

Middle Tennessee Electric Membership Corporation

For MTEMC, typical substation protection consists of a high-side circuit switcher used as the primary protection device with a fault initiation device (aka high speed ground switch) providing back-up protection. A differential relay is used to protect the transformer and sometimes the whole substation dependant upon the zone of protection chosen. In addition, overcurrent relaying (phase & ground) are provided as back-up protection for the transformer. Several types of equipment alarms are used in conjunction with these relays for protection (aka winding temp, loss of dc, oil temp alarms, etc...).

The high-side circuit switcher is immediately tripped if any of the above mentioned devices detect a fault condition requiring station de-energization to clear or fix a fault condition. At MTEMC, the fault initiation device (aka ground switch) is operated under a “circuit switcher failure” type scheme similar to a typical “breaker failure” scheme. If the relaying detects the fault condition 20 cycles after sending the circuit switcher trip signal, then the fault initiation switch is closed. After 20 cycles, a successful circuit switcher operation should have removed all current. If fault current is still detected by the relaying, then the primary protection must have failed and the fault initiation switch is closed. Essentially, the closing of the fault initiation switch creates a bolted fault on the system and results in the opening of TVA’s (our G&T) substation breaker feeding the transmission line, respective substations, and loads. If the fault initiation switch is close to a TVA generation source, then a neutral reactor or resistor is used to reduce the fault current upon closing. This is also helpful in maintaining stability for the rest of the system by minimizing the impact seen. In essence, the fault initiation switch is a “poor man’s transfer trip scheme”.



Westhaven Substation (Circuit Switcher w/fault initiating high speed ground switch)

In addition to the above circuit switcher/fault initiation switch scheme, MTEMC has a few special cases where the MTEMC substations are really close to or part of the TVA transmission substations and fault initiation switches are not used. Instead, direct hard-wired or traditional communication transfer trips are sent to the TVA breaker feeding the MTEMC substation.

The primary protection/backup protection scheme is part of TVA’s protection requirements for all electric utilities across the TVA region.

The distribution feeder breaker protection consists of overcurrent relaying (phase & ground) protecting the equipment from faults on the distribution line. This relaying must be coordinated with upstream and downstream devices to minimize unnecessary outages to unaffected parts of the system. Since studies indicate that the majority of line faults are temporary in nature, reclosing devices are provided inside the breakers to restore power should the faulted condition clear.

New Substation Protection Philosophy

MTEMC’s new substation protection philosophy is essentially the same as mentioned above with the exception of eliminating the fault initiation switch in the protection scheme. The backup protection is now provided by a second circuit switcher that is still delayed by the 20 cycle timer. The backup circuit switcher is treated the same as a fault initiation switch in the sense that we do not allow remote or SCADA closing of the circuit switcher. Obviously, something did not work as it was supposed to and it would be unwise to close in considering the situation. As appropriate with the fault initiation switch, operation of the backup circuit switcher requires a service call to determine why.

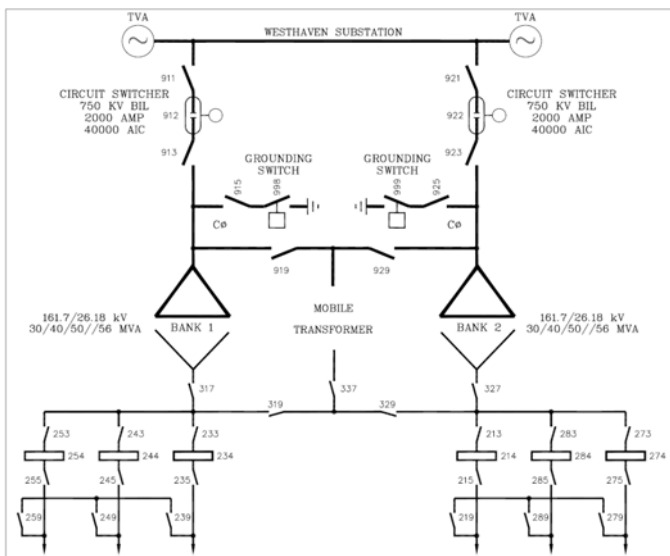

Westhaven Substation (Circuit Switcher w/fault initiating high speed ground switch)

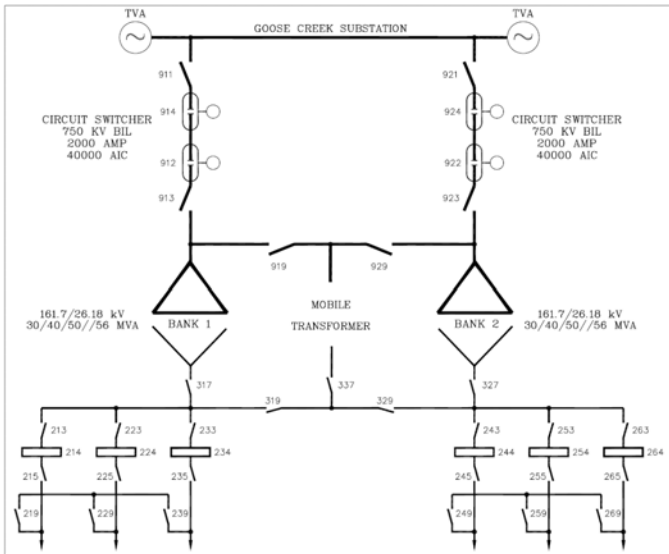

Goose Creek Substation (Circuit Switcher with local, series connected interrupter)



Some utilities in the TVA region are only installing one backup circuit switcher that feeds the two primary circuit switchers, but MTEMC has taken the route of providing true backup and specifies two backup circuit switchers (one behind each primary circuit switcher). We attempt to operate our substations in way that basically gives us two substations in one. The loss of transformer bank 1 doesn't create a loss of transformer bank 2 whether it be a primary or backup operation.

The backup circuit switcher initiative is part of TVA's new requirement across the Tennessee Valley for improving power quality and system stability. The requirement is only for new substations. Existing substations are "grandfathered" in and do not require the backup circuit switcher, but still require the fault initiation switch or other mentioned methods. TVA has agreed to help recover some of the cost associated with the new requirement by reimbursing 1/2 of the cost per backup

circuit switcher installation. Substation projects must be scoped with TVA by this fall to qualify for the reimbursement.

Some of our commercial customer's have noted power quality issues arising from a fault initiation switch closing 100+ miles away on the TVA system. In addition, MTEMC and surrounding utilities may have 6+ substations on a transmission line taken out by the closing of a fault initiation switch. Recently, we experienced a mis-operation of a fault initiation switch that resulted in a city wide outage because three of the substations serving the city were on the same TVA transmission line. MTEMC has experienced other mis-operation issues that have taken out multiple stations. This requires more resources to restore the power in a timely manner for all members affected.

Due to the rising concern about power quality and system stability amongst MTEMC members like Nissan US corporate headquarters, Nissan manufacturing plants, Dell computers, data & payment centers, etc..., MTEMC has started an initiative to remove fault initiation switches in key substations. This initiative may take several years, but it is a move in the right direction.

Implementation of local, series connected interrupters is fairly easy and straightforward with no major hurdles. The biggest issue is the associated cost for the extra circuit switcher, foundations, engineering, monitoring, and control wiring. Another issue for consideration is planning for and taking a substation outage for several weeks to perform the work.

Middle Tennessee Electric Membership Corporation distributes electricity to 180,000 residential and business members to serve a four-county area directly south of metropolitan Nashville. In addition, MTEMC maintains and operates thirty two (32) electrical substations and over 10,000 miles of power lines. Formed by farmers and homeowners in 1936, MTEMC has grown to become the state's largest electric cooperative and the sixth largest in the United States. We strive to provide reliable power to our members and believe that the new substation protection philosophy will enhance that.

IV. CONCLUSION

While the drivers were different for SaskPower and MTEMC, both utilities were able to implement the use of local, series-connected interrupters to provide cost effective solutions that resulted in more reliable system operation.

Larry Taylor is a substation electrical engineer at MTEMC. He has 13 years of experience in the power industry. He graduated from Tennessee Technological University in 1995 with a B.S.E.E and started his career with Clark Control Systems, Inc where he designed and built utility control systems for U.S. and overseas projects. He then worked for R.W. Beck, a consulting firm for two years designing control systems for U.S. and overseas projects. Larry is a registered Professional Engineer.

Charles Shih is the Engineering Supervisor, Substations, Lines & Stations for SaskPower. He has 33 years of experience in the power industry. He graduated from the University of Saskatchewan in 1974 with a B.E.(E.E.) and started his career as Research Officer, College of Engineering at the University of Saskatchewan. In 1975, he joined SaskPower as a design engineer. Charles is a P.Eng., Association of Professional Engineers & Geoscientists of Saskatchewan, Canada.

Tom Speas is the Marketing & Sales Manager of the Power Switching Division of Southern States, LLC located in Hampton, GA. Tom has 32 years of experience in the Utility, Commercial, and Industrial industries. He graduated from Lafayette College in 1976 with a B.S.E.E and started his career in sales with the A.B. Chance Co.