

PRODUCT NEWS

The "Bottom Line" Experience Counts

Do you own an air disconnect switch that has been tagged for the "switch graveyard" or is being carried in inventory because it does not match current application requirements? Why not consider the option preferred by other utilities.

Southern States **Service Division** is dedicated to helping customers keep operating costs down without sacrificing system reliability. We do it through experience. As an original equipment manufacturer since 1916, we are uniquely qualified to provide alternatives to total switch replacement-- alternatives that are developed by experienced service representatives, supported by both application & design engineering, and produced with high-quality material & sound manufacturing processes.

Equipment modifications are not limited to switches initially supplied by Southern States. With our broad product scope and extensive manufacturing capabilities, a solution can be provided for switches furnished by many other manufacturers.

And our commitment does not end with delivery. We are so confident in the quality of our retrofit and upgrade solutions that we cover them with Southern States standard 5-year warranty.

Service Division is serious about contributing to **your** "bottom line". Put us to the test - try one of our customized solutions for your next retrofit or upgrade requirement.

Service Division In Action (Actual Case Study)

Customer Challenge

- Upgrade existing 245 kV vertical break switch from 1200 A to 2000 A continuous current
- Original manufacturer is no longer in business

Our Solution

- Design 2000 A switch live parts to match the original manufacturer's 1200 A insulator spacing
- Utilize all other components of existing switch

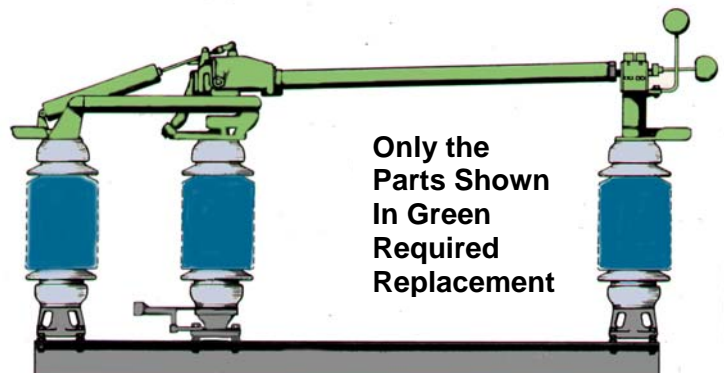

- Difference in purchase price of total switch versus live parts only.
- Ability to reuse structure, insulators, operator, & other control parts including bases
- Reduced outage time & labor costs for removal & replacement of live parts only

Additional Value

- Current switch design
- All components furnished by Southern States are covered by our standard 5-year warranty
- Long-term service & support

30 Georgia Avenue - Hampton, GA 30228 • Phone: 770-946-4562 • Fax: 770-946-8106
 e-mail: support@southernstatesLLC.com website: www.southernstatesLLC.com

24/7 emergency support line: 770-946-4565