



The Quality Name in High Voltage Switching

Type TV70
Aluminum Grounding Switch

72.5 kV – 362 kV

INSTALLATION &

INSTRUCTION

MANUAL

Safety Information

DANGER

IMPROPER HANDLING, INSTALLATION, OPERATION OR MAINTENANCE OF THIS EQUIPMENT MAY CAUSE IMMEDIATE HAZARDS WHICH WILL LIKELY RESULT IN SERIOUS PERSONNEL INJURY OR DEATH.

WARNING

The equipment covered by this publication must be handled, installed, operated and maintained by qualified persons who have direct knowledge and experience dealing with the hazards involved and are thoroughly trained in the handling, installation, operation and maintenance of high voltage transmission and distribution equipment. These instructions are meant for only such **Qualified Persons**. They are not intended to be a substitute for adequate training and experience in safety procedures for this type of equipment.

A **Qualified Person** is one who is trained in and has skills necessary:

- to read and comprehend this instruction book – understanding that these instructions are general in nature
- to accept personal responsibility to prepare and maintain an intrinsically safe work environment and maintain control of the work site to safeguard all persons present
- to develop and implement a proper rigging, lifting, and installation plan along with all safety precautions required to insure safe and proper lifting and installation of the equipment.
- to distinguish between energized and non energized parts
- to determine proper approach distances to energized parts
- to properly work with and around energized or de-energized equipment that may be pressurized with gas
- for proper use of personal protective equipment, insulating and shielding materials, insulated tools for working near energized and /or pressurized electrical equipment
- to recognize and take necessary precautions for the unique and dynamic conditions of site and specialized equipment to maintain a safe work environment during handling, installation, operation, and maintenance of high voltage switching equipment

The instructions in this manual are general guidelines for this type of equipment and not specific to the equipment supplied. Portions of it may not be applicable or may not have complete instructions for your specific equipment.

If you do not understand any part of these instructions or need assistance, contact Southern States Service Division at 770-946-4562 during normal business hours (8:00am – 4:30pm EST, M-F) or 770-946-4565 after normal business hours.

LIMITED WARRANTY

Southern States, LLC (“SLLC”) warrants only to the Warranty Holder (hereinafter defined as the “End User” or the “Immediate Purchaser”, as applicable, pursuant to the terms and conditions of this Limited Warranty as set forth below), that the Product identified below will, upon shipment, be free of defects in workmanship and material for the applicable Warranty Period. The “Warranty Period” is that period of time during which this Limited Warranty is effective, and such period begins on the invoice date issued by SLLC for the Product, and continues until the earlier to occur of (1) the expiration of the Warranty Duration period, or (2) the Number of Operations, both as specified in the table below. If the Product is both purchased and installed within the United States or Canada, this Limited Warranty is granted to each end user of the Product who acquired the Product for its own use during the Warranty Period (“End User”). In all other situations, this Limited Warranty is granted only to the first purchaser of the Product (“Immediate Purchaser”) from SLLC. No primary or remote purchaser or owner of the Product who is not a Warranty Holder may claim any benefit under this Limited Warranty, or any remedial promise included in this Limited Warranty. SLLC shall, upon prompt written notice from the Warranty Holder, correct a nonconforming Product by repair or replacement at the sole discretion of SLLC of the nonconforming Product or any part or component of a nonconforming Product necessary in SLLC’s discretion to make such Product conforming. Any transportation charges, labor for removing, reinstalling the Product or part, and/or costs related to providing access to the Product shall be the responsibility of the Warranty Holder. Correction in this manner will constitute the Warranty Holder’s exclusive remedy and fulfillment of all SLLC’s liabilities and responsibilities hereunder. SLLC’s duty to perform under this limited warranty may be delayed, at SLLC’s sole option, until SLLC has been paid in full for all products purchased by the Warranty Holder. No such delay will extend the Warranty Period. If SLLC does not make such repair or replacement, SLLC’s liability for damages on account of any claimed nonconformity will in no event exceed the purchase price of the Product in question. This Limited Warranty does not apply to any Product that has been disassembled, repaired, or altered by anyone other than SLLC. This Limited Warranty will not apply to any Product that has been subjected to improper or abnormal use of the Product. SLLC has no responsibility to repair or replace any Product or component thereof manufactured by another party, but SLLC will assign, to the extent assignable, to the Warranty Holder any manufacturers’ warranty that applies to products and components not manufactured by SLLC.

THIS LIMITED WARRANTY IS EXCLUSIVE AND IN LIEU OF ALL OTHER WARRANTIES. THERE ARE NO OTHER EXPRESS, IMPLIED, OR STATUTORY WARRANTIES. ALL IMPLIED WARRANTIES WHICH MAY ARISE BY IMPLICATION OF LAW, OR APPLICATION OF COURSE OF DEALING OR USAGE OF TRADE, INCLUDING, BUT NOT LIMITED TO, IMPLIED WARRANTIES OF MERCHANTABILITY OR FITNESS FOR A PARTICULAR PURPOSE, NONINFRINGEMENT OR OTHERWISE ARE EXPRESSLY EXCLUDED. SLLC SHALL NOT BE LIABLE OR RESPONSIBLE FOR ANY CONSEQUENTIAL, INCIDENTAL, INDIRECT, EXEMPLARY, SPECIAL, OR PUNITIVE DAMAGES, EVEN IF SLLC HAS BEEN ADVISED OF THE POSSIBILITY OF SAME. THE WARRANTY HOLDER IS SOLELY RESPONSIBLE FOR THE SUITABILITY OF THE PRODUCT FOR ANY PARTICULAR APPLICATION.

Product Purchased Region	Product Installed Region	Warranty Holder	Warranty Duration
U.S and Canada	U.S and Canada	End User	Five (5) Years
All Other Conditions		Immediate Purchaser	Earlier of 1 year from installation or 18 months from shipment

Type TV70

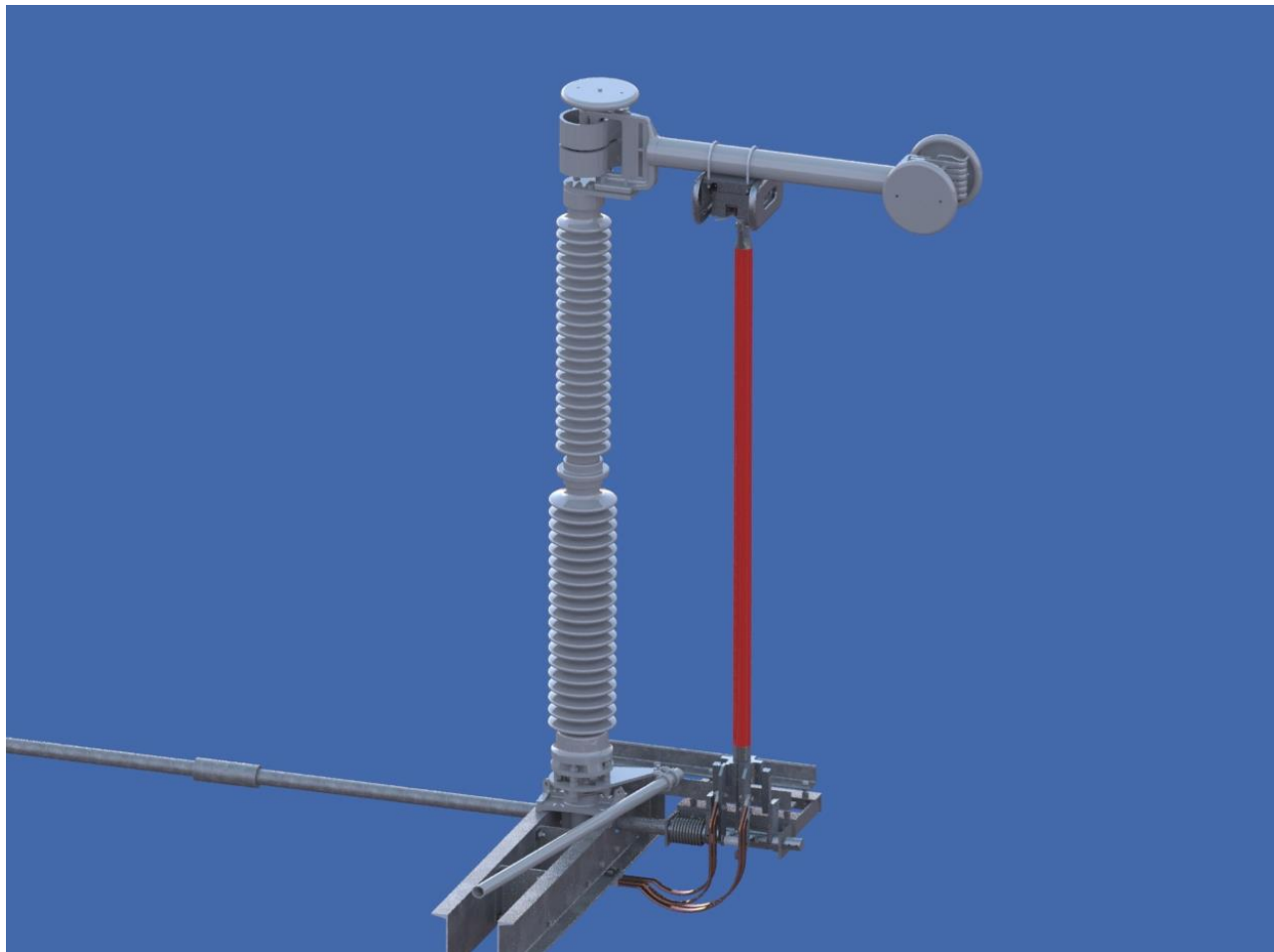

Table of Contents

Chapter	Page
Important	1
Introduction	2
Unpacking.....	2
Storage	2
General Information.....	2
1. Preferred Switch Assembly Method:	4
2. Contact Alignment.....	5
3. Operating Mechanism:	6
Recommended Inspection and Maintenance	13
Patrolling Inspection (6 Months).....	13
Routine Inspection and Maintenance (5 year)	13
Periodic Inspection and Maintenance (10 year)	13

Tables	Page
Table 1: Recommended Tools and Torque Values	3
Table 2: Recommended Installation and Maintenance Table	13

Figures	Page
Figure 1: Blade and Blade clamp.....	4
Figure 2: Jaw contact.....	5
Figure 3: Hinge Adjustment	6
Figure 4: Typical Operating Arrangement.....	7
Figure 5: Type SEGO (Safety Enhanced Gear Operator)	7
Figure 6: Perpendicular to the base.....	8
Figure 7: Parallel to the base	9
Figure 8: Contact engagement	9
Figure 9: Blade Fully Closed.....	11
Figure 10: Adjustable Arm Assembly.....	12

Important

The information contained herein is general in nature and not intended for specific application purposes. It does not relieve the user of responsibility to use sound practices in application, installation, operation, and maintenance of the equipment purchased. Southern States reserves the right to make changes in the specifications shown herein or to make improvements at any time without notice or obligations. Should a conflict arise between the general information contained in this publication and the contents of drawings or supplementary material, or both, the latter shall take precedence.

Introduction

Southern States type TV70 ground switch is generally shipped mounted and adjusted on the line switch whenever the line switch is assembled with its insulators. Depending upon shipping constraints, sometimes this will not be the case and some assembly and adjustment will be required.

This switch can be used on either the jaw or hinge end of the line switch, or both. On center break switches they are arranged so that their jaw is attached to either (or both) line switch blades. They can also be mounted on station post columns, and not attached to the line switch.

Operation can be either three-pole, group operated, or single pole, by manual crank, swing handle or motor drive. And finally, they may be arranged so that their blades open parallel to the base, or perpendicular to it. Blade operation consists of two parts. First in which blade rotates 90° (hinge shaft rotates 90°) in a vertical plane and second where blade moves linearly with blade tip penetrating jaw contacts.

The installation procedures for all these mounting and operating schemes are very similar. Regardless of the configuration, they all use a system of pipes, bearings, and adjustable length arms to open and close the switch from the ground. Some customers use interlocks (mechanical and/or electrical) preventing the line switch and the grounding switch from being closed at the same time. When these are applied make sure all accessory items are installed on the vertical pipe as order of operations is important.

It is important to remember that leveling adjustments to these switches are made to the hardware that supports the grounding switch - not to the hardware that supports the insulator. This is so as not to disturb the adjustments already made to the line switch, which should be installed and operating satisfactorily first.

It may be necessary to make adjustments not described in this manual. If any question should arise during installation or adjustment of this equipment, call your local Southern States representative, or the factory.

Unpacking

Unpack the equipment and check for damages or shortages immediately. The bill-of-material from the Unit Assembly (switch) and Operating Mechanism drawings should be used for this purpose. If damage or a shortage is noted, file a claim immediately with the carrier and contact the factory. For switches that are not shipped assembled, the blades and hinges will be packaged separately from the switch.

Storage

All components of the TV70 ground switch are suitable for outdoor use and do not have any special storage requirements. If a motor operator is furnished be sure to connect the heater circuit, using the provided external wiring, while the unit is in storage. Discard the wiring upon installation. Typical crating is intended for storage less than 1 year. If long term storage is required please notify factory at time of order placement so that special crating can be used.

General Information

All photographs and sketches in this manual are for illustration purposes only and may not be to scale. Refer to the Unit Assembly drawing or the Operating Mechanism drawing provided with each disconnect switch for specific details. During installation, it may be necessary to make adjustments other than those described in this manual. Contact your local representative or the factory if questions should arise.

Southern States After Sales and Service Department is available for field installation assistance along with providing parts support for all Southern States products.

Contact After Sales and Service at 770-946-4562.

Introduction

Table 1: Recommended Tools and Torque Values

Recommended Tools		Recommended Torque Values	
Type	Sizes	Bolt/Nut size	Torque (Ft-lb)
Hand Wrenches and/or Sockets	15/16", 3/4", 5/8", 9/16"	1/2"	50 (S. Steel) 40 (All Others)
Drill Bit	1/4"	5/8"	92
		3/4"	127
		1"	286

General Information

1. Preferred Switch Assembly Method:

- 1.1. If the disconnect is shipped assembled on insulators with ground switch support bracket and blade installed, do not cut the supporting straps and install the switch on the structure and adjust it satisfactorily before proceeding with ground switch installation and adjustment. Skip to Section 2
- 1.2. Install the ground switch hinge to the switch base utilizing the supplied mounting bracket
- 1.3. In the open position install the ground blade ensuring the blade tip is vertical, with the flat part toward the jaw. Insert the blade fully onto support shaft but adjustment may be necessary later. Tighten the blade clamp bolts. Refer to **Figure 1**.
- 1.4. Install each phase in the same manner.

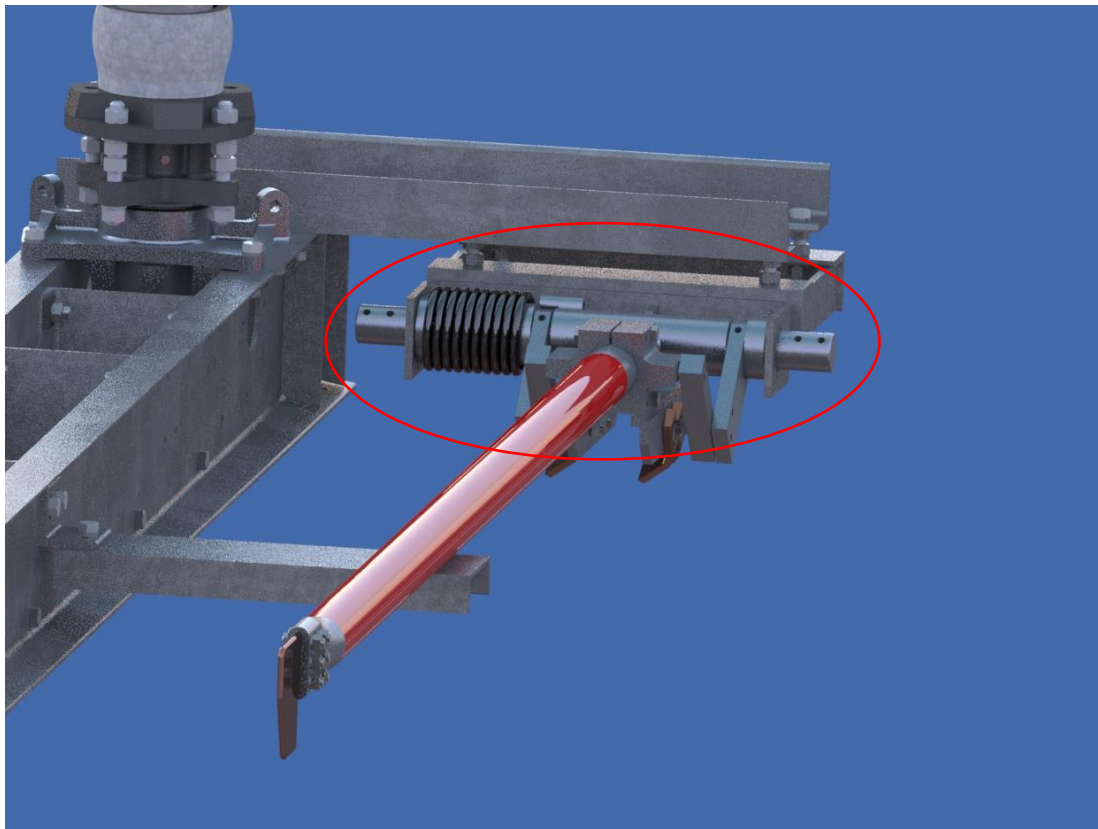

Figure 1: Blade and Blade clamp

- 1.5. If not already installed, attach the jaw in position. If blade mounted leave the bolts loose until fully adjusted.

General Information

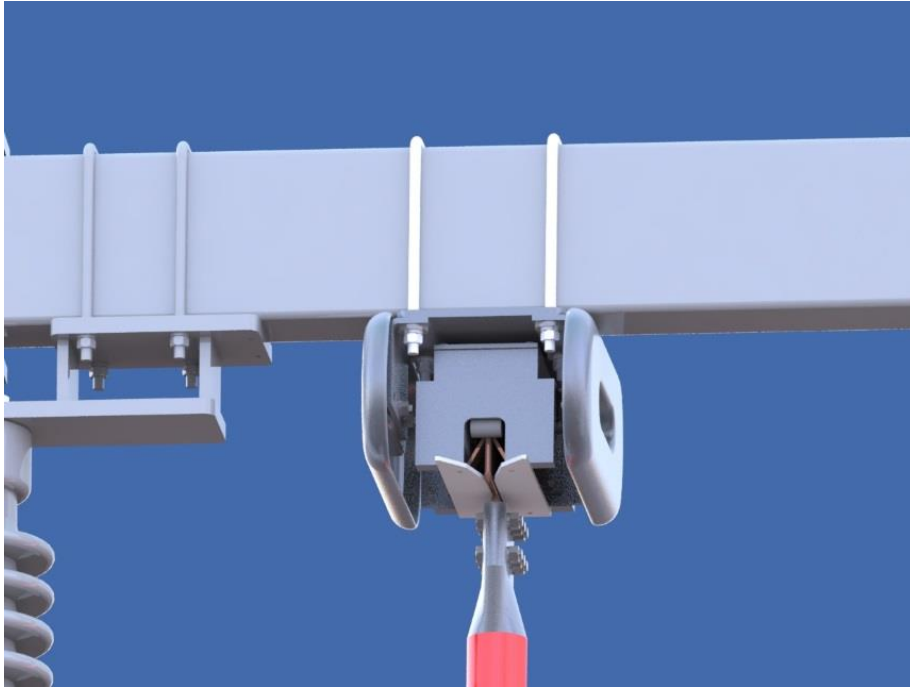

Figure 2: Jaw contact

2. Contact Alignment

- 2.1. Carefully, lift the blade by hand confirming the blade tip is centered in the jaw (**Figure 2**) and the leading edge is in line with the jaw opening. If correct and you haven't done so, tighten the jaw in place and proceed to installing the drive linkage.
- 2.2. If adjustment is necessary, have a helper make adjustments to the mounting bracket and/or blade clamp correcting the issue. Refer to **Figure 3**.
 - 2.2.1. If the blade tip is not in line with the contacts loosen the clamping bolt and twist the blade in its socket until the tip properly adjusted. Tighten the clamping bolt securely.
 - 2.2.2. If the blade is out of line either to the left or right, adjust the jack bolts that support the hinge to tilt the entire hinge left or right as required. First loosen all four nuts "A". Then run both nuts "B" on one side up, and both nuts "B" on opposite side down an equal number of turns. This will pivot the hinge about a central point without changing its height

General Information

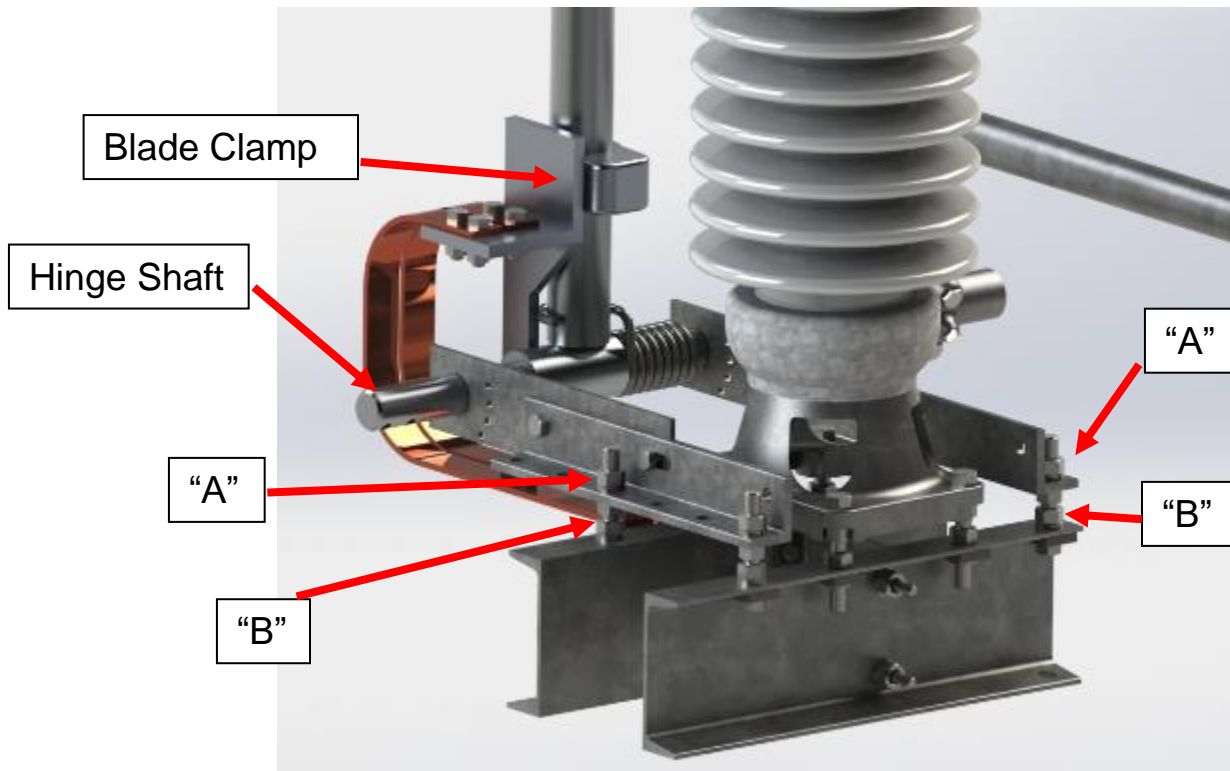

Figure 3: Hinge Adjustment

3. Operating Mechanism:

3.1. Installation

- 3.1.1. Always start in the open position.
- 3.1.2. Refer to the operating mechanism drawing and lay out all parts and check them against the bill of materials.
- 3.1.3. Depending on configuration, either parallel to the base or perpendicular to the base, use the sketch in **Figure 6** or **Figure 7** as a reference and the operating mechanism drawing for specifics and dimensions. Install mounting brackets, bearings, bushings, clevises, operating device, adjustable arm, vertical pipe and reach pipe only **DO NOT** install the interphase pipe at this time. Be sure to install any encircling member (such as key interlock, pipe guide, etc.) on the vertical pipe at this time. NOTE: If the horizontal reach pipe connects directly to the interphase pipe you will have to install it at this time. Focus on adjusting the phase closest to the vertical pipe first, once adjusted properly adjust the remaining phases.
 - 3.1.3.1. For linkages with the interphase pipe going through the switch base it will be provided in sections with a coupling in the middle.
 - 3.1.3.2. **Important:** Prior to installation confirm the adjustable arm has the correct trial dimension shown in the operating mechanism drawing (measure from the centerline of vertical pipe rotation to the centerline of the pinned attachment point. If not loosen and adjust as necessary.

General Information

- 3.1.3.3. If provided, pay close attention to the dimensions shown on the drawings for the initial setup of the lever drive arm shown on the drawings (marked with an "A" in the figures 6 & 7).
- 3.1.4. **Important:** The pipe collar must support the entire weight of the vertical pipe. Do not allow the housing of the manual or motor operator to bear any of the weight of the vertical pipe. See **Figure 4**. Once adjusted properly pierce the pipe collar.

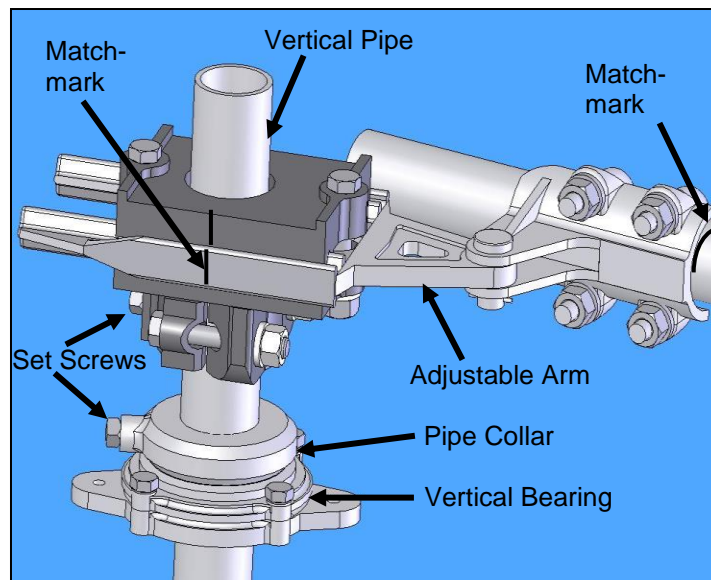

Figure 4: Typical Operating Arrangement

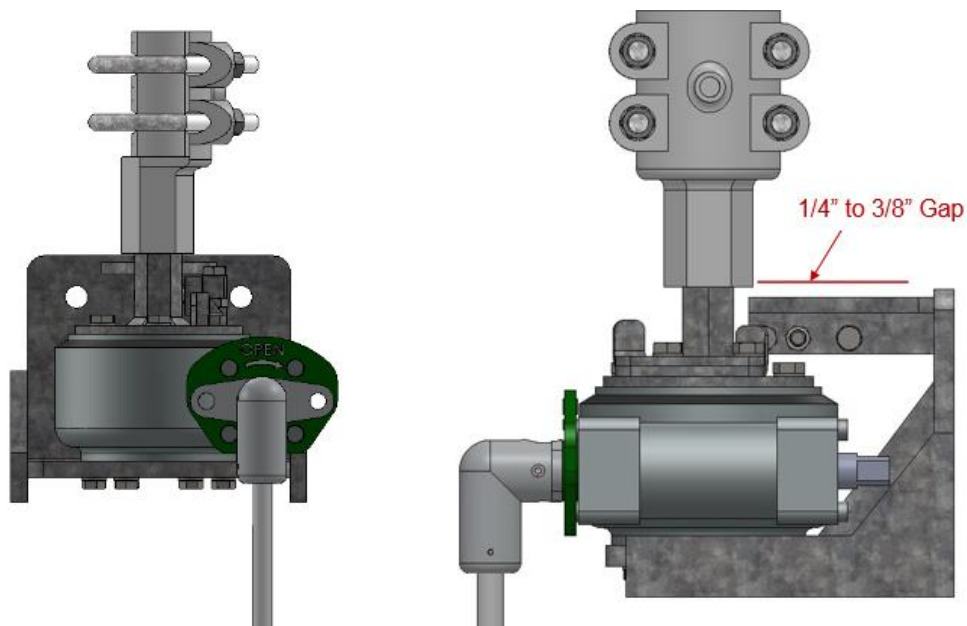

Figure 5: Type SEGO (Safety Enhanced Gear Operator)

General Information

- 3.1.5. Tighten all set screws to grip the pipe securely, but **do not** drive any set screws through the wall of the pipe at this time. Match mark all clevis connections, adjustable arm, and manual operator attachments to check for slippage during trial operations.
- 3.1.6. If motor operator is used, at this point refer to the motor operator installation instructions for mounting and trial operations.
 - 3.1.6.1. The motor operator shall be used in **manual** mode only during setup.

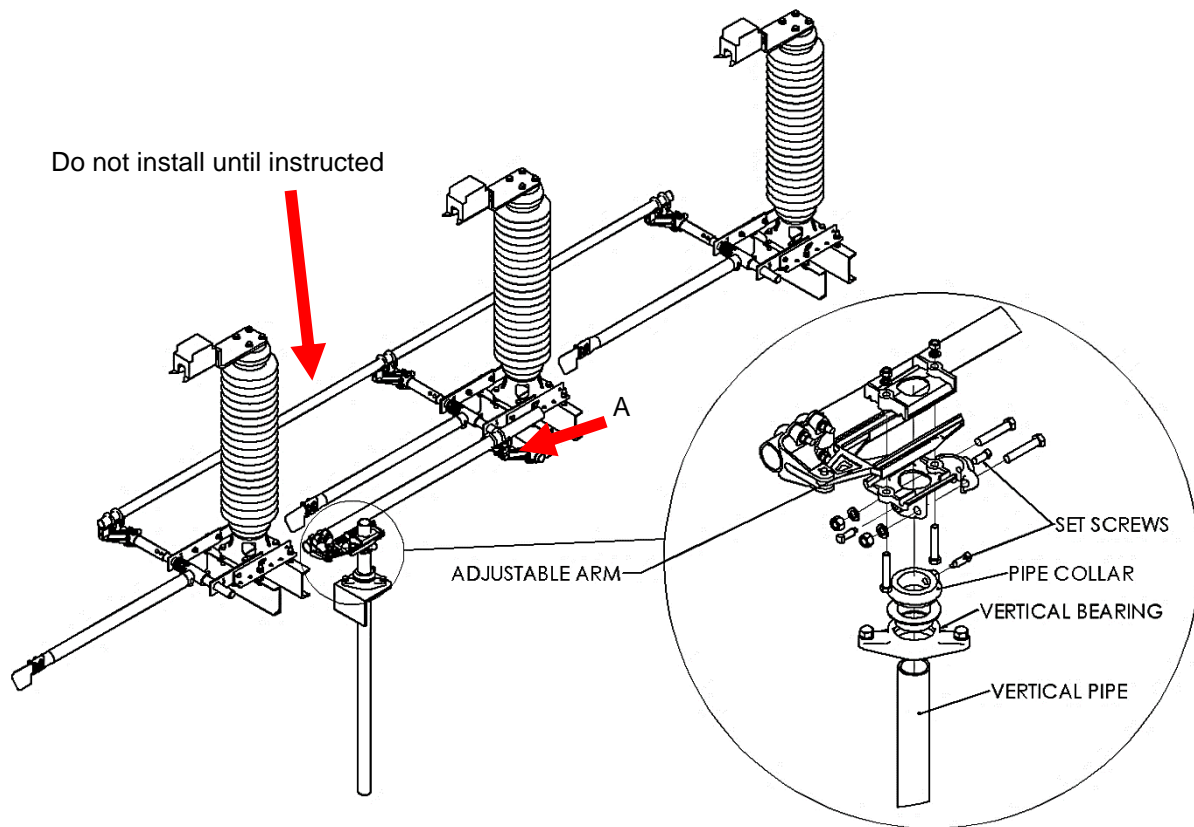

Figure 6: Perpendicular to the base

General Information

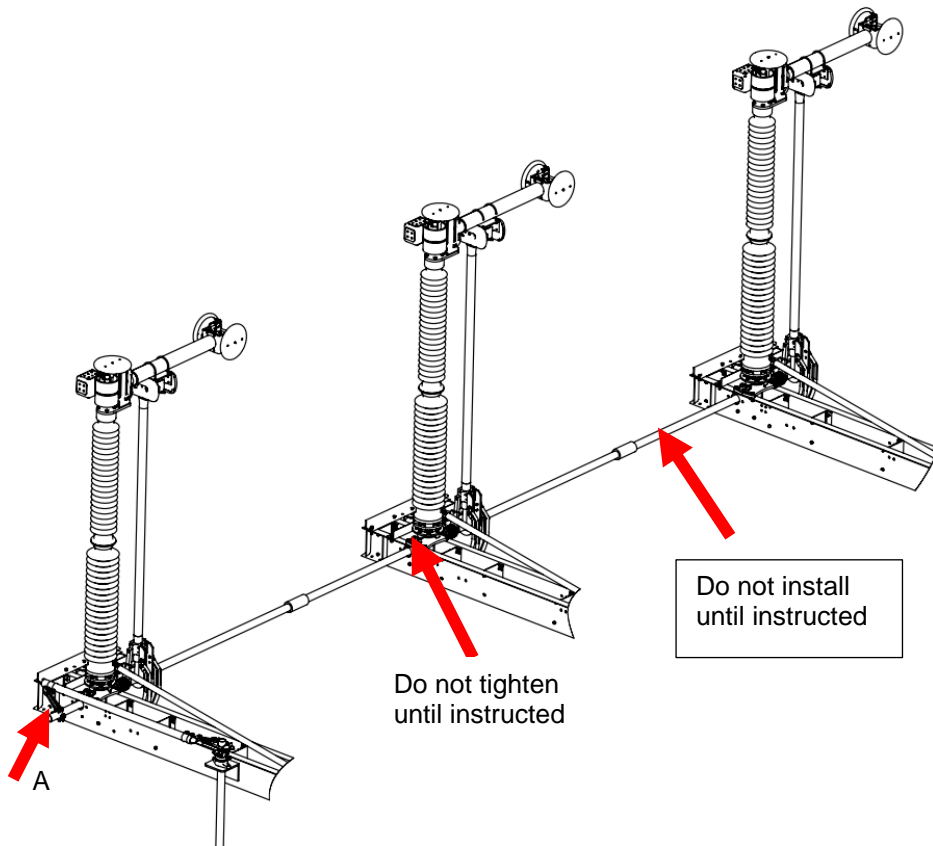

Figure 7: Parallel to the base

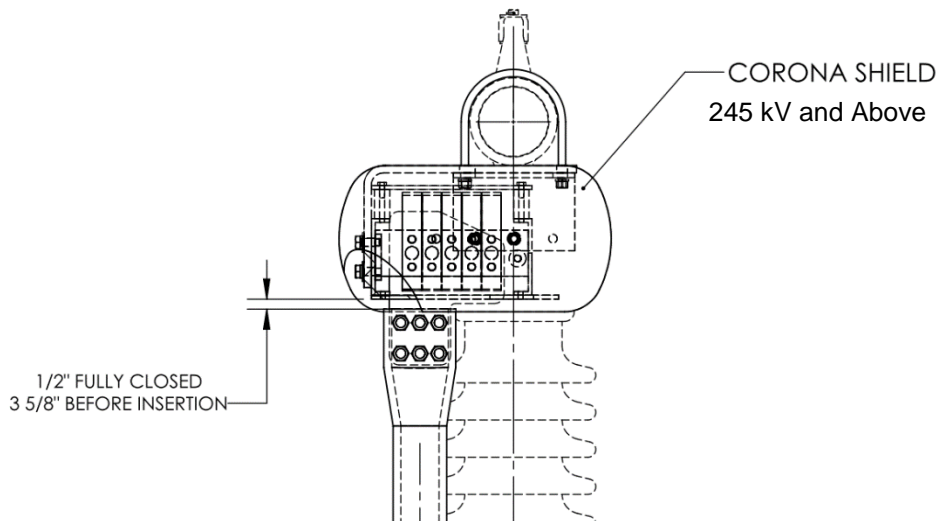

Figure 8: Contact engagement

General Information

3.2. Adjustment:

3.2.1. All grounding switch poles should be open as well as the line switch.

3.2.2. When adjusting the ground switch it is best to adjust the driven phase only if possible.

3.2.2.1. For perpendicular arrangements similar to the one shown in **Figure 6**, this is achieved by connecting the operating pipes to the driven phase only. Once adjusted, open the switch and connect the interphase pipe between all phases. Operate the switch and make adjustments if necessary.

3.2.2.2. For parallel arrangements similar to the one shown in **Figure 7**, this is achieved by connecting the operating pipes to the end phase only. Once adjusted, open the switch and connect the interphase pipe between all phases. Operate the switch and make adjustments if necessary.

3.2.2.3. For parallel arrangements similar to the one shown in **Figure 7**, but with the horizontal drive pipe between two phases, this is achieved by installing the interphase pipe and coupling between the outside phase and the center phase, ensuring the pipe is fully inserted into the hinge shaft for support. Connect the interphase to one switch only by tightening the connection between the pipe and hinge shaft. Once adjusted, open the switch and connect the interphase pipe between all phases. Operate the switch and make adjustments if necessary.

3.2.3. Open/Close criteria defined:

3.2.3.1. Full open, the ground blade is at or near parallel to the switch base.

3.2.3.1.1. If necessary, it is acceptable to be above parallel but not above the switch base as long as no physical interference is created.

3.2.3.2. Full closed, this is a 2 step process. Refer to **Figure 9**

3.2.3.2.1. Step 1: As the blade tip enters the jaw it is fully centered and firmly against the blade stop. There should be a vertical gap between the aluminum portion of the blade and bottom of the jaw contact support of 3-5/8 inches. See **Figure 8**.

3.2.3.2.2. Step 2: The blade will now lift vertically. It is in the full closed position when the gap between the aluminum portion of the blade and bottom of the jaw contact support is 1/2 inch. See **Figure 8**.

3.2.3.2.3. It may be required to raise the ground switch mounting bracket slightly (preferred) or loosen the blade in the clamp and extend it slightly (acceptable) to achieve the required dimensions of Step 2.

General Information

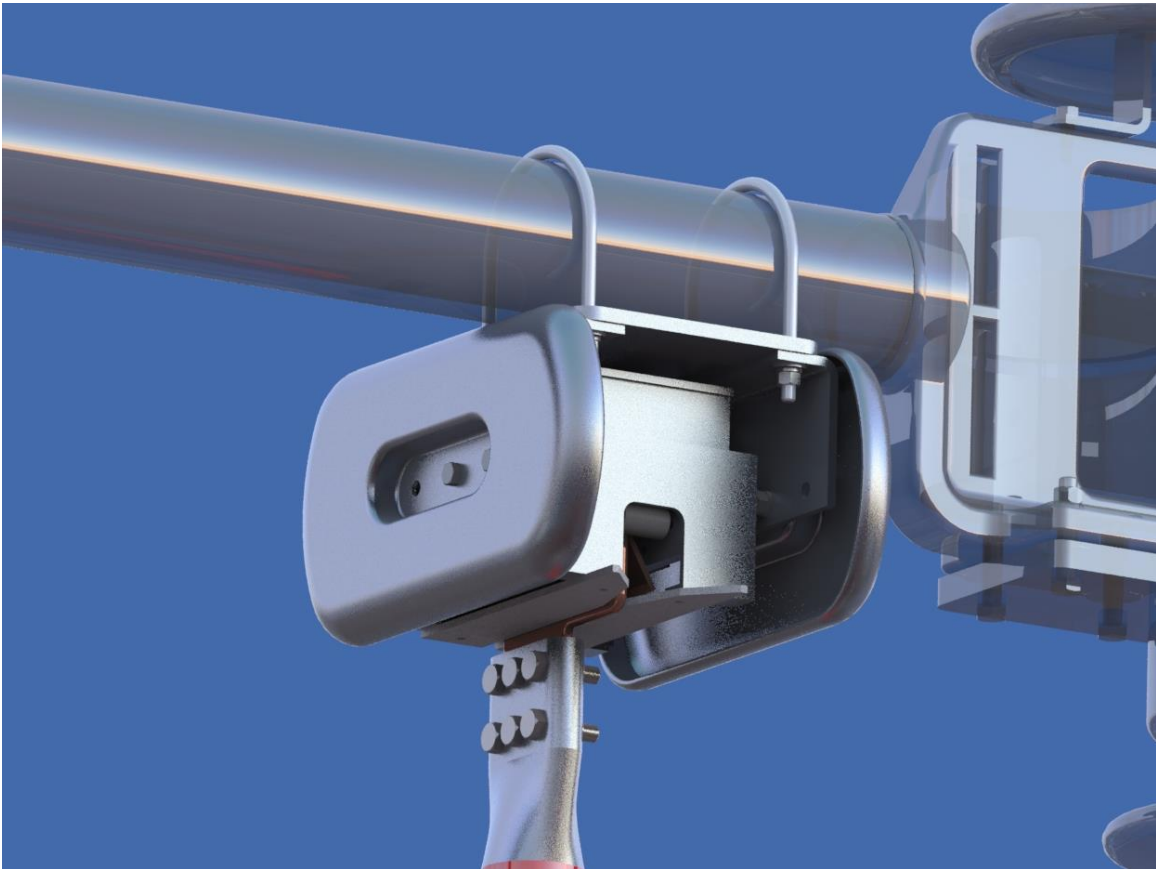

Figure 9: Blade Fully Closed

- 3.2.4. Close the switch. The adjustable arm should travel 180° from toggle open to the closed position.
 - 3.2.4.1. If the adjustable arm rotates 180° and neither Step 1 nor Step 2 are achieved, the radius of the adjustable arm is too short or something has slipped.
 - 3.2.4.1.1. Check first to see that nothing has slipped.
 - 3.2.4.1.2. Return the switch to the open position.
 - 3.2.4.1.3. Match mark, then loosen the adjustable arm and clevis bolts as shown in
 - 3.2.4.1.4. **Figure 10.**
 - 3.2.4.1.5. Lengthen the radius of the adjustable arm 1/4 to 1/2 inch and allow the clevis to reposition itself the same distance (lengthening the pipe). Small changes make big differences.
 - 3.2.4.1.6. Test operate again and adjust as necessary.

General Information

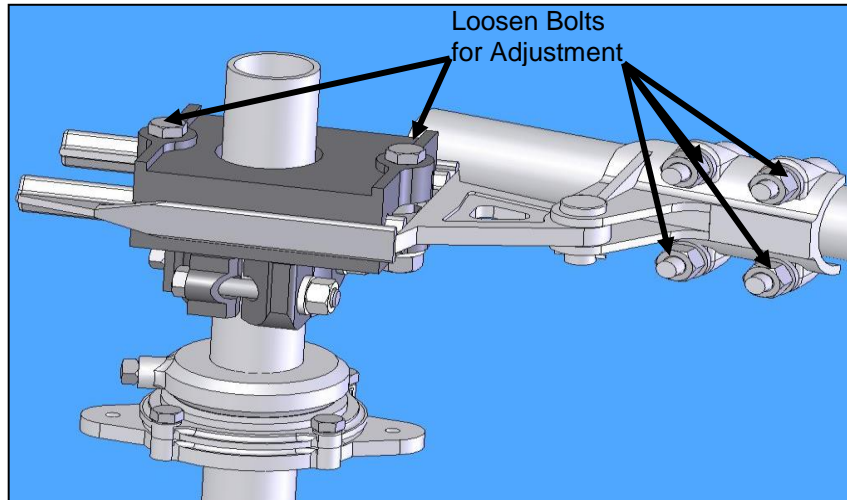

Figure 10: Adjustable Arm Assembly

3.2.4.2. If the switch is fully closed before the adjustable arm rotates 180°, the radius of the adjustable arm is too long. **Be careful not to overdrive the blade into the contacts.**

3.2.4.2.1. Check to see that nothing has slipped.

3.2.4.2.2. Return the switch to the open position.

3.2.4.2.3. Loosen the adjustable arm and clevis bolts as shown in

3.2.4.2.4. **Figure 10.**

3.2.4.2.5. Shorten the radius of the adjustable arm 1/4 to 1/2 inch and allow the clevis to reposition itself the same distance (shortening the pipe). Small changes make big differences

3.2.4.2.6. Test operate again and adjust as necessary.

HINT: Due to pipe twist and system losses you may find that one phase will not quite go

All poles of the fully adjusted switch should operate simultaneously within +/- 5°. The main objective is for all switches to completely open and completely close. Slight adjustment of the interphase clevises may be necessary to coordinate all three poles. When the switch is completely adjusted, securely tighten all bolts and tighten all set screws until the pipe walls are pierced. (For heavy wall pipe, drill the set screw holes, using the threaded drill guides supplied and a 1/4" drill.)

Recommended Inspection and Maintenance

The TV70 has been designed to operate with low maintenance. Periodic inspection is important for satisfactory operation. Frequency of inspection and maintenance depends on the installation site, weather and atmospheric conditions, experience of operating personnel and special operation requirements.

Table 2: Recommended Installation and Maintenance Table

		Installation Tests	Patrolling Inspection 6 month	Routine 5 Year	Periodic 10 Year
Insulators	Contamination	X	X	X	X
	Damage	X	X	X	X
Cabinet (if motor operator supplied)	Any loose parts on the floor of the cabinet?	X	X	X	X
	Wiring Secure	X	X	X	X
	Links Secure	X	X	X	X
	Inspect Mechanism for loose parts	X	X	X	X
	Heaters Energized	X	X	X	X
	Door Seal	X	X	X	X
Mechanical	Operational Tests	X		X	X
Liveparts Inspection	Inspect Contacts				X

Patrolling Inspection (6 Months)

The patrolling inspection is a largely visual inspection on an energized unit in service. The frequency of the inspection is determined by the local conditions and policies of the owner of the equipment. Refer to **Table 2** for recommended inspection items.

Routine Inspection and Maintenance (5 year)

Routine inspection is performed on a de-energized unit. The frequency of the inspection is determined by the local conditions and policies of the owner of the equipment. Refer to **Table 2** for recommended inspection items.

Periodic Inspection and Maintenance (10 year)

Periodic inspection is performed on a de-energized unit. The frequency of the inspection is determined by the local conditions and policies of the owner of the equipment. Refer to **Table 2** for recommended inspection items.

ANSI Standard C37.30.1 Annex D is also a recommended guide for maintenance on air disconnect switches.



Southern States

The Quality Name in High Voltage Switching

30 Georgia Avenue
Hampton, Georgia 30228
Phone: 770-946-4562
Fax: 770-946-8106
E-mail: support@southernstatesllc.com
<http://www.southernstatesllc.com>

©2017 Southern States, LLC
Printed U.S.A.

IB-306-TV70-R2 081517